

SAE Flanges
Specifications:

SAE-J518/ISO 6162, Hydraulic flanged tube, pipe and hose connections, four-bolt split flange type

Material Specifications:

ST52.3

SS316

Size Range:

Code 61 (Series 3000) : 3/8"NB – 5"NB

Code 62 (Series 6000) : 3/8"NB – 3"NB

Working Pressure:

Code 61 (Series 3000) : 34 – 345 Bar

Code 62 (Series 6000) : 200 – 414 Bar

Temperature:

Carbon steel: -40°C - +120°C

Stainless steel: -60°C - +50°C

Working pressure for material stainless steel shall be reduced if exceed certain temperature:

40% above +50°C to < +100°C

11% above +100°C to < +200°C

20% above +200°C to < +250°C

Orings:

NBR (Standard) , Viton (Optional)

Flange Screws:

Metric screws according to DIN 912-8.8 (Standard)

Metric screws according to DIN 912-10.9 (Optional)

SAE Flange Recommended Torque Values
Code 61 (Series 3000)

Flange Size	Recommended Torque Range N/m
1/2"	32
3/4"	70
1"	70
1 1/4"	70
1 1/2"	130
2"	130
2 1/2"	130
3"	295
3 1/2"	295
4"	295
5"	295

Code 62 (Series 6000)

Flange Size	Recommended Torque Range N/m (+10% -0)
1/2"	32
3/4"	70
1"	130
1 1/4"	130
1 1/2"	295
2"	550
2 1/2"	550
3"	650



INDEX

TYPE	PAGE NO
WELD IN DOUBLE FLANGES	3
WELD ON DOUBLE FLANGES SCHXXS	4
WELD ON DOUBLE FLANGES SCH160	5
WELD ON DOUBLE FLANGES SCH80	6
WELD ON FLANGE HEAD	7
CUT SPLIT FLANGES	8
UNCUT SPLIT FLANGES	9

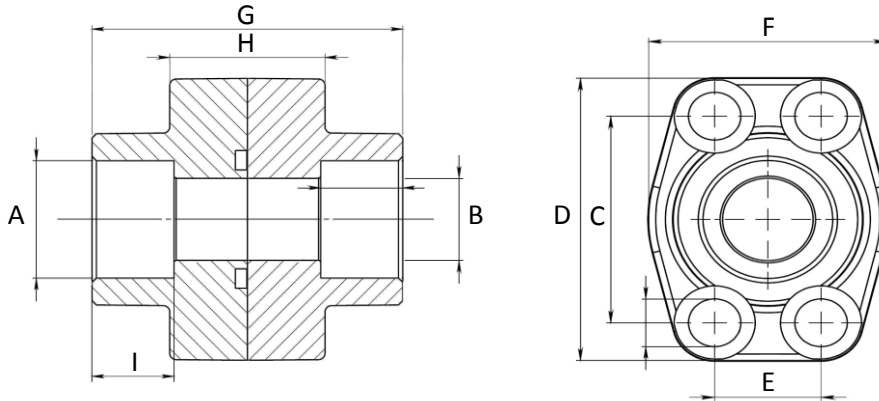
WELD IN DOUBLE FLANGES

SERIES 3000

WP (Bar)	Size	Type	Dimensions									
			A	B	C	D	E	F	G	H	I	Screws
345	1/2"	DFS080S	21.6	13	38.10	54	17.48	46	72	32	19	M8 x 30
345	1/2"	DFS080S038	17.5	13	38.10	54	17.48	46	72	32	19	M8 x 30
345	3/4"	DFS100S	27.2	19	47.63	65	22.23	50	72	36	19	M10 x 35
345	1"	DFS102S	34.0	25	52.37	70	26.19	55	76	36	19	M10 x 35
276	1 1/4"	DFS104S	42.8	32	58.72	79	30.18	68	82	42	22	M10 x 40
207	1 1/2"	DFS106S	48.6	38	69.85	93	35.71	78	90	50	24	M12 x 45
207	2"	DFS108S	61.0	51	77.77	102	42.88	90	90	50	26	M12 x 45
172	2 1/2"	DFS110S	76.6	63	88.90	114	50.80	105	100	50	30	M12 x 45
138	3"	DFS112S	90.5	73	106.38	134	61.93	124	100	54	34	M16 x 50
34	3 1/2"	DFS114S	103.0	89	120.65	152	69.85	136	96	54	34	M16 x 50
34	4"	DFS116S	115.5	97	130.18	162	77.77	146	96	54	34	M16 x 50
34	5"	DFS118S	141.3	120	152.40	184	92.08	180	100	56	28	M16 x 50

SERIES 6000

WP (Bar)	Size	Type	Dimensions									
			A	B	C	D	E	F	G	H	I	Screws
414	1/2"	DFS401S012	21.6	13	40.49	57	18.24	46	72	32	19	M8 x 30
414	1/2"	DFS401S038	17.5	13	40.49	57	18.24	46	72	32	19	M8 x 30
414	3/4"	DFS402S	27.2	19	50.80	71	23.80	55	70	42	22	M10 x 40
414	1"	DFS403S	34.0	25	57.15	81	27.76	65	82	42	22	M12 x 45
414	1 1/4"	DFS404S	42.8	32	66.68	95	31.75	78	88	50	25	M14 x 45
414	1 1/2"	DFS405S	48.6	38	79.38	112	36.50	94	100	60	28	M16 x 50
414	2"	DFS406S	61.0	51	96.82	134	44.45	114	130	74	24	M20 x 70
414	2 1/2"	DFS507S	76.6	63	123.80	180	58.70	152	160	90	30	M24 x 80
414	3"	DFS508S	90.5	73	152.40	208	71.40	178	180	110	30	M30 x 100

Designation for Order:

Double Flanges

(Flat side & Oring side)

ST52.3	DFS...STB..
SS316	DFX...STB..

Counter-Flanges

(Oring side)

ST52.3	DFS...STB..
SS316	DFX...STB..

Flanges

(Flat side)

ST52.3	DFS...STB..
SS316	DFX...STB..

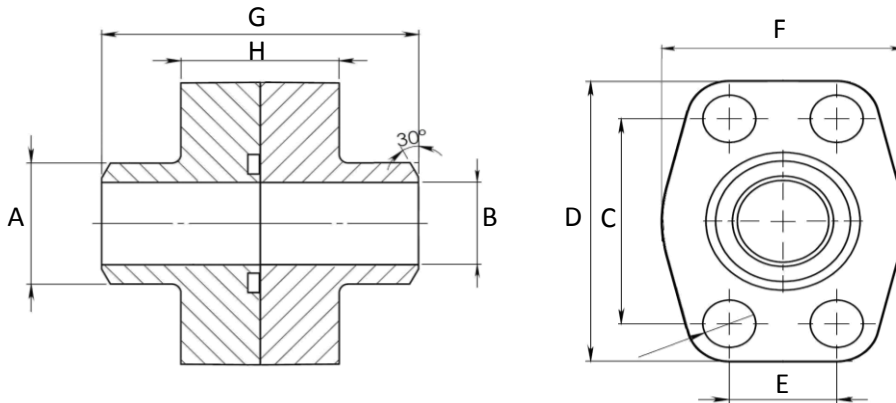
WELD ON DOUBLE FLANGES SCHXXS

SERIES 3000

WP (Bar)	Size	Type	Dimensions									
			A	B	C	D	E	F	G	H	I	Screws
345	1/2"	DFS080STB6	21.5	6.3	38.10	54	17.48	46	72	32		M8 x 30
345	3/4"	DFS100STB11	28.0	11.0	47.63	65	22.23	50	72	36		M10 x 35
345	1"	DFS102STB15	34.0	15.2	52.37	70	26.19	55	76	36		M10 x 35
276	1 1/4"	DFS104STB22	42.8	22.8	58.72	79	30.18	68	82	42		M10 x 40
207	1 1/2"	DFS106STB28	48.6	28.0	69.85	93	35.71	78	90	50		M12 x 45
207	2"	DFS108STB38	61.0	38.2	77.77	102	42.88	90	90	50		M12 x 45
172	2 1/2"	DFS110STB45	77.0	45.0	88.90	114	50.80	105	100	50		M12 x 45
138	3"	DFS112STB58	92.0	58.4	106.38	134	61.93	124	100	54		M16 x 50
34	4"	DFS116STB80	115.5	80.0	130.18	162	77.77	146	96	54		M16 x 50
34	5"	DFS118STB102	141.3	102.9	152.40	184	92.08	180	100	56		M16 x 50

SERIES 6000

WP (Bar)	Size	Type	Dimensions									
			A	B	C	D	E	F	G	H	I	Screws
414	1/2"	DFS401STB012B6	21.5	6.3	40.49	54	18.24	46	72	32		M8 x 30
414	3/4"	DFS402STB11	28.0	11.0	50.80	71	23.80	55	70	42		M10 x 40
414	1"	DFS403STB15	34.0	15.2	57.15	81	27.76	65	82	42		M12 x 45
414	1 1/4"	DFS404STB22	42.8	22.8	66.68	95	31.75	78	88	50		M14 x 45
414	1 1/2"	DFS405STB28	48.6	28.0	79.38	112	36.50	94	100	60		M16 x 50
414	2"	DFS406STB38	61.0	38.2	96.82	134	44.45	114	130	74		M20 x 70
414	2 1/2"	DFS507STB45	76.6	45.0	123.80	180	58.70	152	160	90		M24 x 80
414	3"	DFS508STB58	90.0	58.4	152.40	208	71.40	178	180	110		M30 x 100

Designation for Order:

 Double Flanges
 (Flat side & Oring side)

ST52.3	DFS...STB..
SS316	DFX...STB..

 Counter-Flanges
 (Oring side)

ST52.3	DFS...STB..
SS316	DFX...STB..

 Flanges
 (Flat side)

ST52.3	DFS...STB..
SS316	DFX...STB..

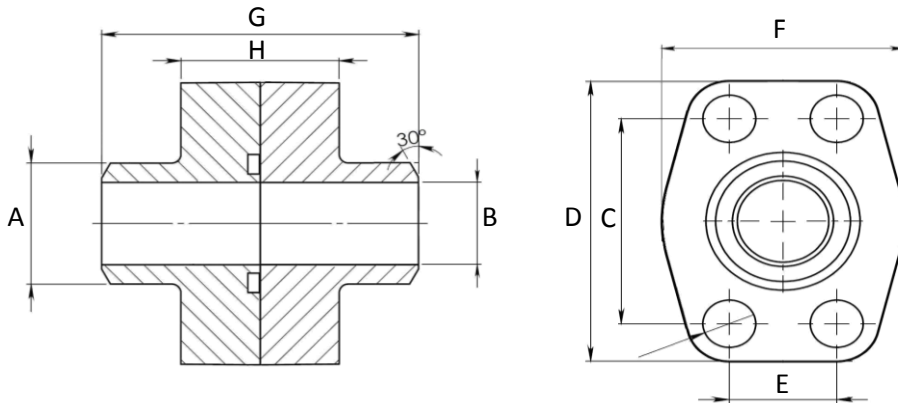
WELD ON DOUBLE FLANGES SCH160

SERIES 3000

WP (Bar)	Size	Type	Dimensions									
			A	B	C	D	E	F	G	H	I	Screws
345	1/2"	DFS080STB11	21.5	11.8	38.10	54	17.48	46	72	32		M8 x 30
345	3/4"	DFS100STB15	28.0	15.6	47.63	65	22.23	50	72	36		M10 x 35
345	1"	DFS102STB20	34.0	20.7	52.37	70	26.19	55	76	36		M10 x 35
276	1 1/4"	DFS104STB29	42.8	29.5	58.72	79	30.18	68	82	42		M10 x 40
207	1 1/2"	DFS106STB34	48.6	34.0	69.85	93	35.71	78	90	50		M12 x 45
207	2"	DFS108STB42	61.0	42.8	77.77	102	42.88	90	90	50		M12 x 45
172	2 1/2"	DFS110STB54	77.0	54.0	88.90	114	50.80	105	100	50		M12 x 45
138	3"	DFS112STB67	92.0	67.7	106.38	134	61.93	124	100	54		M16 x 50
34	4"	DFS116STB87	115.5	87.3	130.18	162	77.77	146	96	54		M16 x 50
34	5"	DFS118STB109	141.3	109.5	152.40	184	92.08	180	100	56		M16 x 50

SERIES 6000

WP (Bar)	Size	Type	Dimensions									
			A	B	C	D	E	F	G	H	I	Screws
414	1/2"	DFS401ST012B11	21.5	11.8	40.49	54	18.24	46	72	32		M8 x 30
414	3/4"	DFS402STB15	28.0	15.6	50.80	71	23.80	55	70	42		M10 x 40
414	1"	DFS403STB20	34.0	20.7	57.15	81	27.76	65	82	42		M12 x 45
414	1 1/4"	DFS404STB29	42.8	29.5	66.68	95	31.75	78	88	50		M14 x 45
414	1 1/2"	DFS405STB34	48.6	34.0	79.38	112	36.50	94	100	60		M16 x 50
414	2"	DFS406STB42	61.0	42.8	96.82	134	44.45	114	130	74		M20 x 70
350	2 1/2"	DFS507STB54	76.6	54.0	123.80	180	58.70	152	160	90		M24 x 80
350	3"	DFS508STB67	90.0	67.7	152.40	208	71.40	178	180	110		M30 x 100

Designation for Order:

Double Flanges

(Flat side & Oring side)

ST52.3	DFS...STB..
SS316	DFX...STB..

Counter-Flanges

(Oring side)

ST52.3	DFS...STB..
SS316	DFX...STB..

Flanges

(Flat side)

ST52.3	DFS...STB..
SS316	DFX...STB..

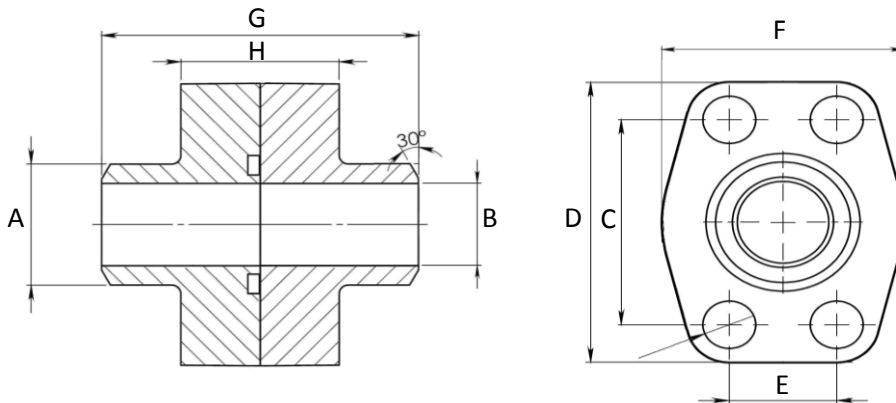
WELD ON DOUBLE FLANGES SCH80

SERIES 3000

WP (Bar)	Size	Type	Dimensions									
			A	B	C	D	E	F	G	H	I	Screws
345	1/2"	DFS080ST	21.5	13.0	38.10	54	17.48	46	72	32		M8 x 30
345	1/2"	DFS080ST038	17.5	13.0	38.10	54	17.48	46	72	32		M8 x 30
345	3/4"	DFS100ST	28.0	19.0	47.63	65	22.23	50	72	36		M10 x 35
345	1"	DFS102ST	34.0	25.0	52.37	70	26.19	55	76	36		M10 x 35
276	1 1/4"	DFS104ST	42.8	32.0	58.72	79	30.18	68	82	42		M10 x 40
207	1 1/2"	DFS106ST	48.6	38.0	69.85	93	35.71	78	90	50		M12 x 45
207	2"	DFS108ST	61.0	49.0	77.77	102	42.88	90	90	50		M12 x 45
172	2 1/2"	DFS110ST	77.0	59.0	88.90	114	50.80	105	100	50		M12 x 45
138	3"	DFS112ST	92.0	73.0	106.38	134	61.93	124	100	54		M16 x 50
34	3 1/2"	DFS114ST	103.0	85.0	120.65	152	69.85	136	96	54		M16 x 50

SERIES 6000

WP (Bar)	Size	Type	Dimensions									
			A	B	C	D	E	F	G	H	I	Screws
414	1/2"	DFS401ST012	21.5	13.0	40.49	54	18.24	46	72	32		M8 x 30
414	1/2"	DFS401ST038	17.5	13.0	40.49	54	18.24	46	72	32		M8 x 30
414	3/4"	DFS402ST	28.0	19.0	50.80	71	23.80	55	70	42		M10 x 40
414	1"	DFS403ST	34.0	25.0	57.15	81	27.76	65	82	42		M12 x 45
375	1 1/4"	DFS404ST	42.8	32.0	66.68	95	31.75	78	88	50		M14 x 45
320	1 1/2"	DFS405ST	48.6	38.0	79.38	112	36.50	94	100	60		M16 x 50
250	2"	DFS406ST	61.0	49.0	96.82	134	44.45	114	130	74		M20 x 70
230	2 1/2"	DFS507ST	76.6	59.0	123.80	180	58.70	152	160	90		M24 x 80
200	3"	DFS508ST	90.0	73.0	152.40	208	71.40	178	180	110		M30 x 100

Designation for Order:

 Double Flanges
 (Flat side & Oring side)

ST52.3	DFS...ST
SS316	DFX...ST

 Counter-Flanges
 (Oring side)

ST52.3	DFS...ST
SS316	DFX...ST

 Flanges
 (Flat side)

ST52.3	DFS...ST
SS316	DFX...ST

WELD ON FLANGE HEAD

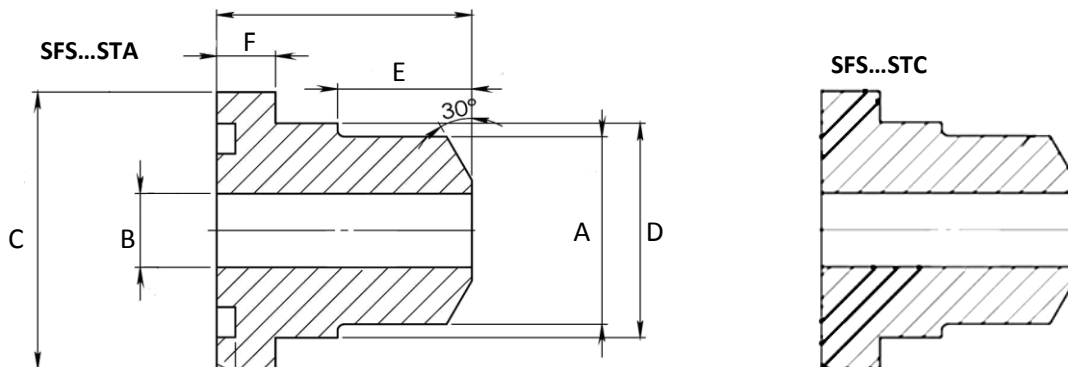

SERIES 3000

WP (Bar)	Size	Type	Dimensions					
			A	B	C	D	E	F
345	1/2"	SFS301STA21B6	21.5	6.3	30.2	24	41	6.73
345	3/4"	SFS302STA28B11	28.0	11.0	38.1	32	50	6.73
345	1"	SFS303STA34B15	34.0	15.2	44.4	38	50	8.00
276	1 1/4"	SFS304STA42B22	42.8	22.8	50.8	43	55	8.00
207	1 1/2"	SFS305STA50B28	50.0	28.0	60.3	50	57	8.00
207	2"	SFS306STA61B38	61.0	38.2	71.4	62	57	9.53
172	2 1/2"	SFS307STA74B54	74.0	54.0	84.1	74	58	9.53
138	3"	SFS308STA90B66	90.0	66.0	101.6	90	60	9.53
34	3 1/2"	SFS309STA102B76	102.0	76.0	114.3	102	80	11.20
34	4"	SFS311STA114B87	114.3	87.0	127.0	114.3	80	11.20
34	5"	SFS311STA139B107	139.7	107.0	152.4	139.7	80	11.20

SERIES 6000

WP (Bar)	Size	Type	Dimensions					
			A	B	C	D	E	F
414	1/2"	SFS601STA21B6	21.5	6.3	31.8	24	34	7.75
414	3/4"	SFS602STA28B11	28.0	11.0	41.3	32	38	8.76
414	1"	SFS603STA34B15	34.0	15.2	47.6	38	40	9.53
414	1 1/4"	SFS604STA42B22	42.8	22.8	54.0	44	45	10.29
414	1 1/2"	SFS605STA50B28	50.0	28.0	63.5	51	50	12.57
414	2"	SFS606STA61B38	61.0	38.2	79.4	67	58	12.57

Designation for Order:

Counter-Flanges

(Oring side)

ST52.3	SFS...STA
SS316	SFX...STA

Flanges

(Flat side)

ST52.3	SFS...STCA
SS316	SFX...STCA

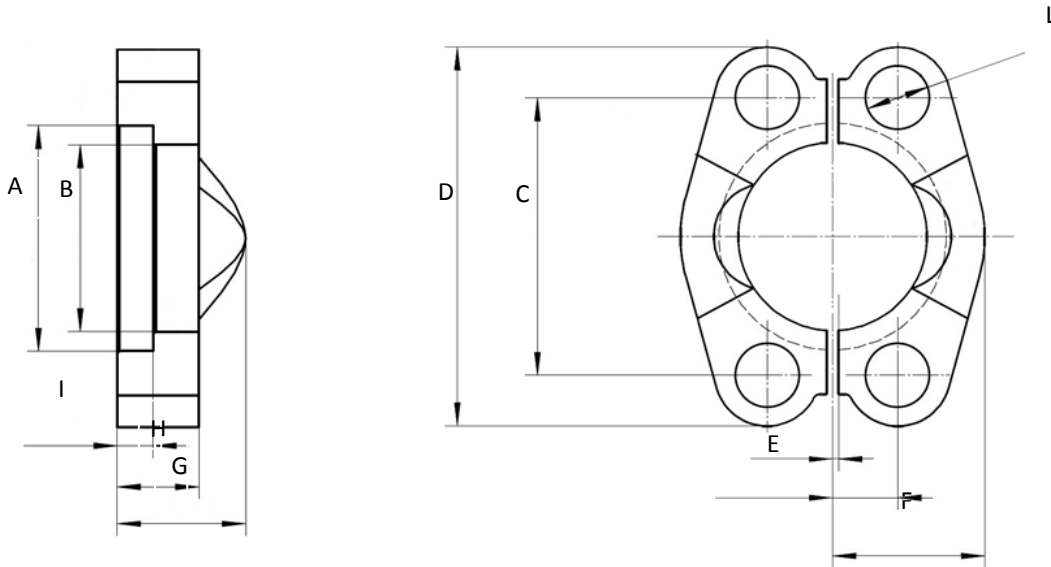
CUT SPLIT FLANGES

SERIES3000

WP (Bar)	Size	Type	Dimensions									
			A	B	C	D	E	F	G	H	I	Screws / L
345	1/2"	AFS301	30.96	24.26	38.10	54	8.74	22.8	19	13	6.22	M8 x 30
345	3/4"	AFS302	38.89	32.13	47.63	65	11.13	25.9	22	14	6.22	M10 x 35
345	1"	AFS303	45.24	38.48	52.37	70	13.08	29.2	24	16	7.49	M10 x 35
276	1 1/4"	AFS304	51.59	43.69	58.72	79	15.09	36.3	22	14	7.49	M10 x 35
207	1 1/2"	AFS305	61.09	50.80	69.85	94	17.86	41.1	25	16	7.49	M12 x 35
207	2"	AFS306	72.24	62.74	77.77	102	21.44	48.2	26	16	9.02	M12 x 35
172	2 1/2"	AFS307	84.94	74.93	88.90	114	25.40	54.1	38	19	9.02	M12 x 40
138	3"	AFS308	102.39	90.93	106.38	135	30.96	65.3	41	22	9.02	M16 x 50
34	3 1/2"	AFS309	115.10	102.36	120.65	152	34.92	69.5	28	22	10.72	M16 x 50
34	4"	AFS310	127.79	115.06	130.18	162	38.88	76.0	35	25	10.72	M16 x 50
34	5"	AFS311	153.19	140.46	152.40	184	46.04	90.0	41	28	10.72	M16 x 50

SERIES 6000

WP (Bar)	Size	Type	Dimensions									
			A	B	C	D	E	F	G	H	I	Screws / L
414	1/2"	AFS601	32.54	24.64	40.49	56	9.12	23.6	22	16	7.24	M8 x 30
414	3/4"	AFS602	42.06	32.51	50.80	71	11.91	30.0	28	19	8.26	M10 x 35
414	1"	AFS603	48.41	38.86	57.15	81	13.89	34.8	33	24	9.02	M12 x 45
414	1 1/4"	AFS604	54.76	44.45	66.68	95	15.88	38.6	38	27	9.78	M14 x 45
414	1 1/2"	AFS605	64.29	51.56	79.38	113	18.26	47.5	43	30	12.07	M16 x 50
414	2"	AFS606	80.16	67.56	96.82	133	22.23	56.9	52	37	12.07	M20 x 70

Designation for Order:

Cut Split-Flanges

ST52.3	AFS...
SS316	AFX...

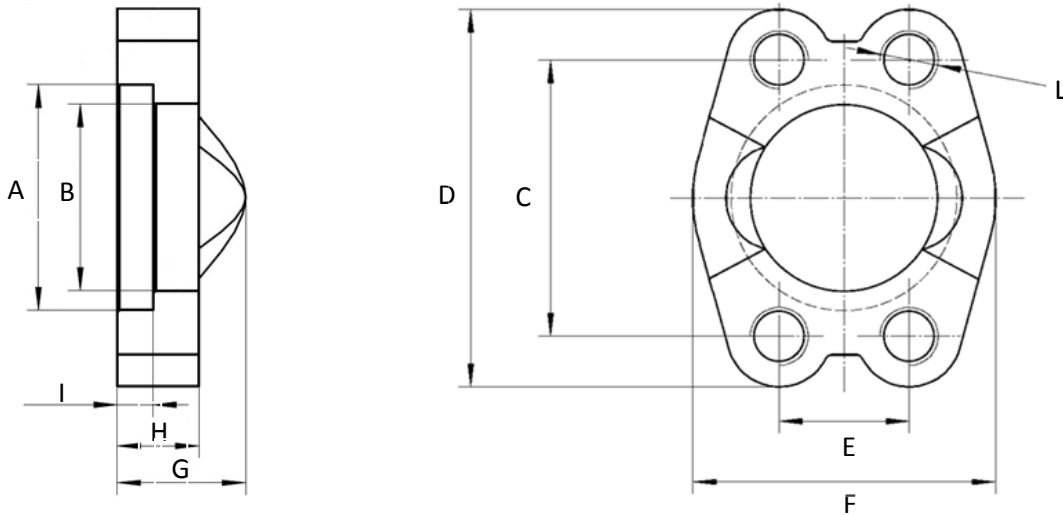
UNCUT SPLIT FLANGES

SERIES3000

WP (Bar)	Size	Type	Dimensions									
			A	B	C	D	E	F	G	H	I	Screws / L
345	1/2"	AFSI301	30.96	24.26	38.10	54	17.48	45.6	19	13	6.22	M8 x 30
345	3/4"	AFSI302	38.89	32.13	47.63	65	22.23	51.8	22	14	6.22	M10 x 35
345	1"	AFSI303	45.24	38.48	52.37	70	26.19	58.4	24	16	7.49	M10 x 35
276	1 1/4"	AFSI304	51.59	43.69	58.72	79	30.18	72.6	22	14	7.49	M10 x 35
207	1 1/2"	AFSI305	61.09	50.80	69.85	94	35.71	82.2	25	16	7.49	M12 x 35
207	2"	AFSI306	72.24	62.74	77.77	102	42.88	96.4	26	16	9.02	M12 x 35
172	2 1/2"	AFSI307	84.94	74.93	88.90	114	50.80	108.2	38	19	9.02	M12 x 40
138	3"	AFSI308	102.39	90.93	106.38	135	61.93	130.6	41	22	9.02	M16 x 50
34	3 1/2"	AFSI309	115.10	102.36	120.65	152	69.85	139.0	28	22	10.72	M16 x 50
34	4"	AFSI310	127.79	115.06	130.18	162	77.77	152.0	35	25	10.72	M16 x 50
34	5"	AFSI311	153.19	140.46	152.40	184	92.08	180.0	41	28	10.72	M16 x 50

SERIES 6000

WP (Bar)	Size	Type	Dimensions									
			A	B	C	D	E	F	G	H	I	Screws / L
414	1/2"	AFSI601	32.54	24.64	40.49	56	18.24	47.2	22	16	7.24	M8 x 30
414	3/4"	AFSI602	42.06	32.51	50.80	71	23.80	60.0	28	19	8.26	M10 x 35
414	1"	AFSI603	48.41	38.86	57.15	81	27.76	69.6	33	24	9.02	M12 x 45
414	1 1/4"	AFSI604	54.76	44.45	66.68	95	31.75	77.2	38	27	9.78	M14 x 45
414	1 1/2"	AFSI605	64.29	51.56	79.38	113	36.50	95.0	43	30	12.07	M16 x 50
414	2"	AFSI606	80.16	67.56	96.82	133	44.45	113.8	52	37	12.07	M20 x 70

Designation for Order:

 Uncut Split Flanges
 (Without bolt thread)

ST52.3	AFSI...
SS316	AFXI...

 Uncut Split Flanges
 (With with bolt thread)

ST52.3	GFSI...
SS316	GFXI...

Chuan Kok Hardware & Machinery Pte Ltd

Address: 1783 Geylang Bahru #01-02, Kallang Distripark Singapore 339708

Telephone Number: +65 6294 2566

Fax Number: +65 6295 7013

Email Address: info@chuankok.com

Website: www.chuankok.com

Business Registration Number: 198201577Z

Country of Registration: Singapore

Conditions of Use of Catalogue

The information in the catalogue are not binding and in order to improve distribution, Chuan Kok Hardware & Machinery Pte Ltd reserves the right to make any change including size and pressure ratings considered necessary at any time and without prior notice.

According to the copyright and the civil law, any reproduction (also partial) of figures and texts of this catalogue by means of electronic, mechanical, photocopies, microfilms, recordings or other is forbidden without Chuan Kok Hardware & Machinery Pte Ltd's authorization.

Catalogue Version: 1215