

# GLOBE VALVES

## JIS10K Cast Iron Flange End Globe Valves



### JIS 10K Cast Iron Flange End Globe Valves

#### Features

- JIS 10K Flange Connection
- Size: 2" – 4" (DN50 – DN100)
- Valve Body Material: Cast Iron
- Working Pressure: 10kg/cm<sup>2</sup>
- Applicable Medium: General oil, gas and water applications
- Temperature range: ≤ 230°C



#### Material List

No.	Part Name	Material
1	Body	FC
2	Seat	FC
3	Disc	FC
4	Cover	A29 1025
5	Stem	A276 410
6	Gasket	SS304 + Graphite
7	Bolts	A29 1035
8	Nuts	A29 1025
9	Bonnet	FC
10	Stem Nut	A276 410
11	Handwheel	A47 32510
12	Nut	A29 1025
13	Screw	SS304
14	Nut	A29 1025
15	Bolt	A29 1035
16	Gland Flange	FC
17	Packing Gland	A276 410
18	Packing	Flexible Graphite
19	Back Seat	A276 410

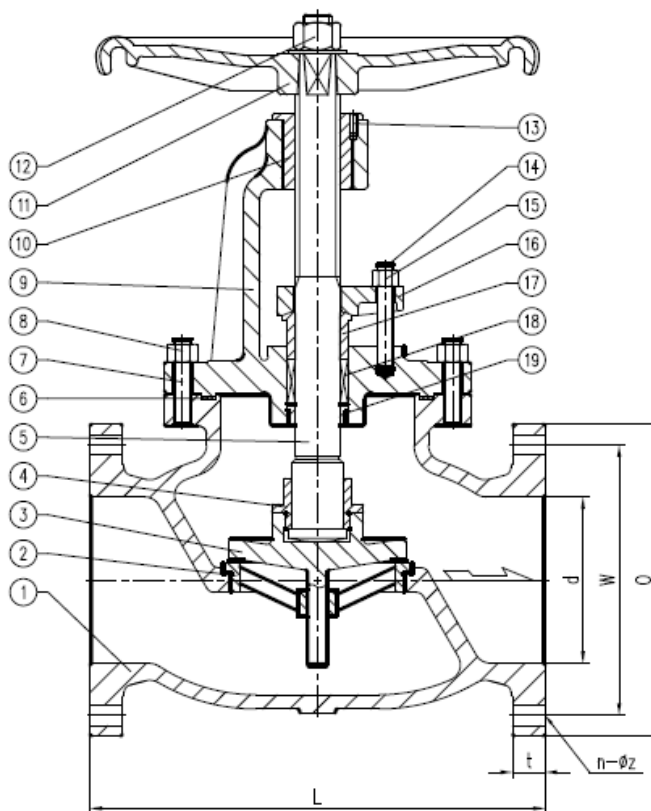

#### Technical Specifications

1. Basic design and manufacture according to JIS F7307
2. Face to face dimension: JIS F7307
3. Flange End: JIS B2210
4. Inspection and test: JIS F7400

Main Technical Parameter			
Normal pressure		10K	
Test pressure	Hydraulic body test	2.06	MPa
	Seal test	1.57	
	Hermetical seal test	0.6	
Max working temperature		≤ 230°C	
Applicable Medium: General oil, gas & water			

### JIS 10K Cast Iron Flange End Globe Valve

#### Features

- JIS 10K Flange Connection
- Size: 5" – 6" (DN125 – DN150)
- Valve Body Material: Cast Iron
- Working Pressure: 10kg/cm<sup>2</sup>
- Applicable Medium: General oil, gas and water applications
- Temperature range: ≤ 429°C



#### Material List

No.	Part Name	Material
1	Body	ASTM A126 B
2	Seat	ASTM A126 B + SS304
3	Disc	ASTM A126 B + SS304
4	Cover	ASTM A29 1025
5	Stem	ASTM A276 410
6	Gasket	SS304 + Graphite
7	Bolts	ASTM A29 1035
8	Nuts	ASTM A29 1025
9	Bonnet	ASTM A126 B
10	Stem Nut	ASTM A276 410
11	Handwheel	ASTM A47 32510
12	Nut	ASTM A29 1025
13	Screw	SS304
14	Nuts	ASTM A29 1025
15	Bolts	ASTM A29 1035
16	Gland Flange	ASTM A126 B
17	Packing Gland	ASTM A276 410
18	Pin	ASTM A29 1025
19	Packing	Flexible Graphite

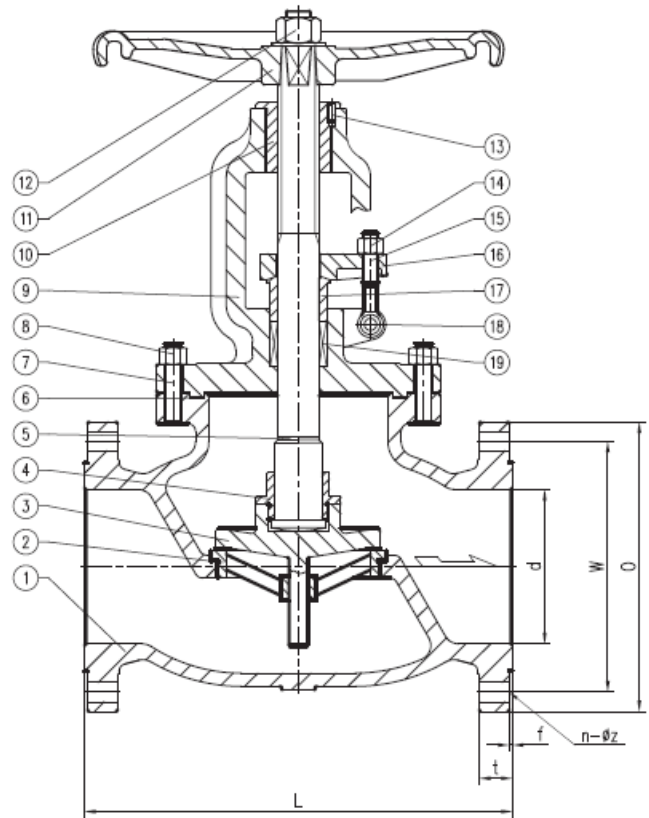

#### Technical Specifications

- Basic design and manufacture according to ASME B16.10
- Face to face dimension: ASME B16.10
- Flange End: JIS B2212
- Inspection and test: API598

Main Technical Parameter			
Normal pressure		10K	
Test pressure	Hydraulic body test	2.06	MPa
	Seal test	1.57	
	Hermetical seal test	0.6	
Max working temperature		≤ 429°C	
Applicable Medium: General oil, gas & water			

**Ordering Information**

VL - CI - GL - F - 10K - 32  
 I II III IV V VI

**I Type of Item**

VL Low Pressure Valves

**II Material Grade**

S	SS316, CF8M	CI	Cast Iron
FS	Forged Steel	CS	Cast Steel
B	Brass		

**III Item**

GA	Gate Valve	B1	1 PC Ball Valve
GL	Globe Valve	B2	2 PC Ball Valve
YS	Y-Strainer	B3	3 PC Ball Valve
SC	Swing Check Valve	BL	3 Way Ball Valve L Port
VC	Vertical Check Valve	BT	3 Way Ball Valve T Port
WC	Wafer Check Valve	BMF	Male x Female Mini Ball Valve
DD	Dual Disk	BU	Butterfly Valve

**IV Connection Type**

SW	S/W	G	BSPP
BW	B/W	N	NPT
R	BSPT	F	Flange End
W	Wafer	L	Lug

**V Pressure**

200	200 PSI	2000	2000 PSI
300	300 PSI	150	ANSI 150# Flange Standard
600	600 PSI	10K	JIS 10K Flange Standard
800	800 PSI	PN16	PN 16 Flange Standard
1000	1000 PSI		

**For Inch OD & Inch NB Sizes**
**VI Size**

Size	1/8"	1/4"	5/16"	3/8"	1/2"	5/8"	3/4"	1"
Code	02	04	05	06	08	10	12	16
Size	1 1/4"	1 1/2"	2"	2 1/2"	3"	4"	5"	6"
Code	20	24	32	40	48	64	80	96

**VII Coating**

(None) No Additional Coating  
 NI Nickel Plating

**Dimension List**
**DN50 – DN100**

NPS	Part No	d	L	O	W	n – Øz	t	Weight (Kg)
2"	VL-CI-GL-F-10K-32	50	222	154	122	4-Ø19	21	18.60
2-1/2"	VL-CI-GL-F-10K-40	65	272	175	142	4-Ø19	22	27.80
3"	VL-CI-GL-F-10K-48	80	300	185	153	8-Ø19	23	32.00
4"	VL-CI-GL-F-10K-64	100	352	210	177	8-Ø19	25	47.00

**DN125 – DN150**

NPS	Part No	d	L	O	W	n – Øz	t	f	Weight (Kg)
5"	VL-CI-GL-F-10K-80	125	330	254	213	8-Ø22	23.9	2	47.60
6"	VL-CI-GL-F-10K-96	150	355	279	244	8-Ø22	25.4	2	68.00

**Part Number Reference**

Impa Code	Part No	Description
75 02 31	VL-CI-GL-F-10K-32	2"JIS10K CI FLANGE END GLOBE VALVE FF, NON-RISING STEM, JIS F7307
75 02 32	VL-CI-GL-F-10K-40	2 1/2"JIS10K CI FLANGE END GLOBE VALVE FF, NON-RISING STEM, JIS F7307
75 02 33	VL-CI-GL-F-10K-48	3"JIS10K CI FLANGE END GLOBE VALVE FF, NON-RISING STEM, JIS F7307
75 02 34	VL-CI-GL-F-10K-64	4"JIS10K CI FLANGE END GLOBE VALVE FF, NON-RISING STEM, JIS F7307
-	VL-CI-GL-F-10k-80	5"JIS10K CI FLANGE END GLOBE VALVE RF, NON-RISING STEM, SS304 TRIM
-	VL-CI-GL-F-10k-96	6"JIS10K CI FLANGE END GLOBE VALVE RF, NON-RISING STEM, SS304 TRIM

## Chuan Kok Hardware & Machinery Pte Ltd

Address : 1783 Geylang Bahru, #01-02, Singapore 339708  
Telephone Number : +65 6294 2566  
Email Address : [info@chuankok.com](mailto:info@chuankok.com)  
Website : [www.chuankok.com](http://www.chuankok.com)  
Business Registration Number : 198201577Z  
Country of Registration : Singapore

### Conditions of Use of Catalogue:

The information in the catalogue are not binding and in order to improve distribution, Chuan Kok Hardware & Machinery Pte Ltd reserves the right to make any change including size and pressure ratings considered necessary at any time and without prior notice. According to the copyright and the civil law, any reproduction (also partial) of figures and texts of this catalogue by means of electronic, mechanical, photocopies, microfilms, recordings or other is forbidden without Chuan Kok Hardware & Machinery Pte Ltd's authorization.  
Catalogue Version: 2021

