

GLOBE VALVES

ANSI 150# SS316 Globe Valves



ANSI 150# SS316 Flange End Globe Valves

Features

- ANSI 150# Flange Connection
- Size: 1" – 1 1/2" (DN25 – DN40)
- Valve Body Material: SS316
- Working Pressure: 150#
- Applicable Medium: General oil, gas and water applications
- Temperature Range: -29°C to 425°C



Material List

No.	Part Name	Material
1	Body + Seat	ASTM A182 F316
2	Disc	ASTM A182 F316
3	Stem	ASTM A182 F316
4	Gasket	SS316 + Graphite
5	Bonnet	ASTM A182 F316
6	Bonnet Bolt	ASTM A193 B8M
7	Packing	Graphite
8	Pin	ASTM A182 F316
9	Gland	ASTM A182 F316
10	Gland Flange	ASTM A182 F316
11	Gland Bolt	ASTM A193 B8M
12	Gland Nut	ASTM A194 8M
13	Yoke Sleeve	ASTM A276 410
14	Lock Nut	Carbon Steel
15	Handwheel	ASTM A197

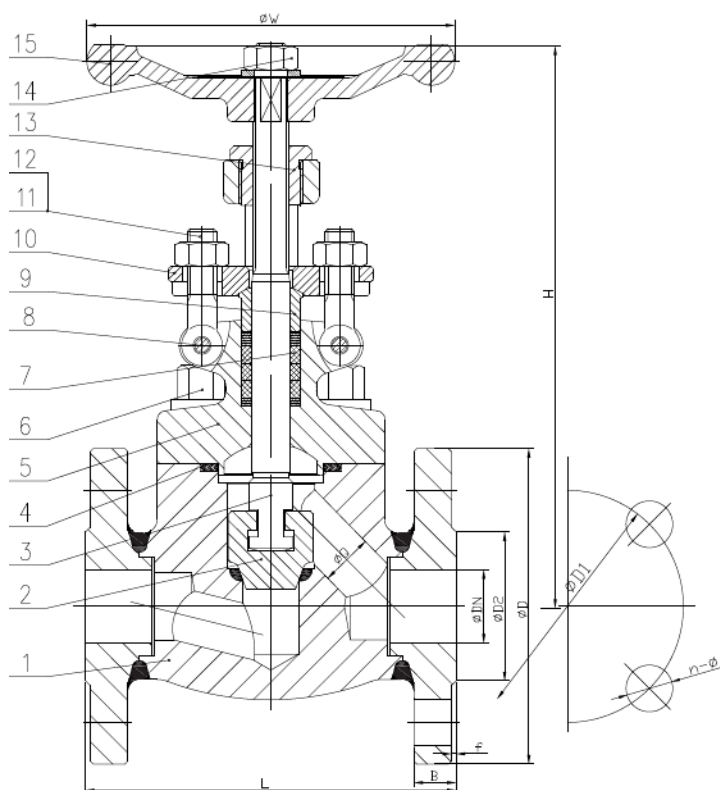

Technical Specifications

1. Basic design and manufacture according to API602/BS5352
2. Face to face dimension: ASME B16.10
3. Flange End: ASME B16.5 RF
4. Inspection and test: API 598

Main Technical Parameter			
Normal pressure		150 PSI	
Test pressure	Shell test pressure	3.0	MPa
	Seal test	2.2	
	Gas test	0.6	
Max working temperature		-29°C to 425°C	
Applicable Medium: General oil, gas & water			

ANSI 150# SS316 Flange End Globe Valves

Features

- ANSI 150# Flange Connection
- Size: 2" – 4" (DN50 – DN100)
- Valve Body Material: SS316
- Working Pressure: 150#
- Applicable Medium: General oil, gas and water applications
- Temperature range: $\leq 425^{\circ}\text{C}$



Material List

No.	Part Name	Material
1	Body	A351 CF8M
2	Disc	SS316
3	Grand	SS316
4	Stem	SS316
5	Bolt	A193 B8M
6	Nut	A194 B8M
7	Gasket	SS316 + Graphite
8	Packing	Graphite
9	Pin	SS304
10	Gland Nut	SS316
11	Packing Gland	A351 CF8M
12	Eye bolt	A193 B8M
13	Bonnet	A351 CF8M
14	Stem Nut	A439 D2
15	Screw	AISI 1025
16	Handwheel	A216 WCB
17	Gasket	SS316
18	Nut	A194 B8M

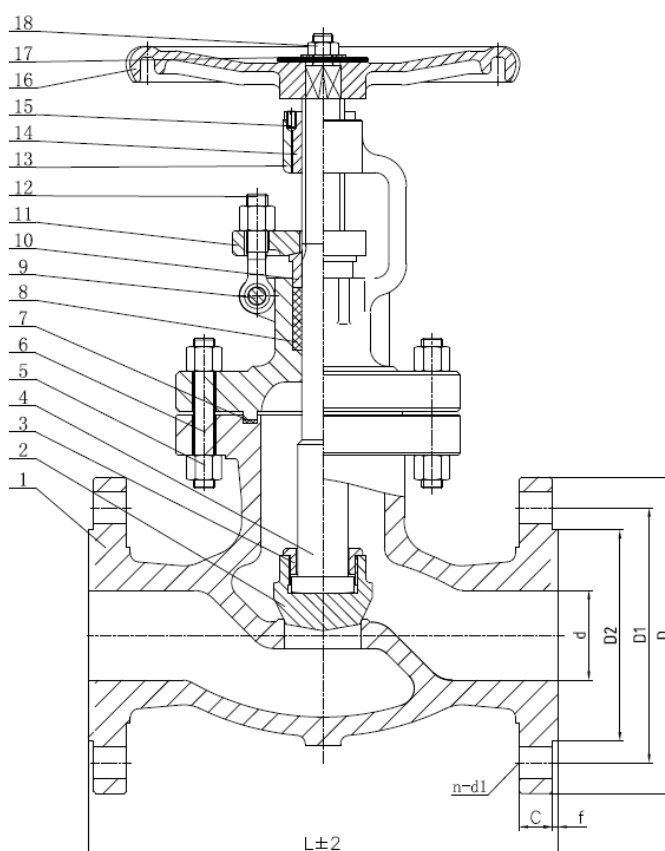

Technical Specifications

1. Basic design and manufacture according to ASME B16.34 & BS 1873
2. Face to face dimension: ASME B16.10
3. Flange End: ASME B16.5
4. Inspection and test: API 598

Main Technical Parameter			
Normal pressure		150 PSI	
Test pressure	Shell test pressure	3.0	MPa
	Seal test	2.2	
	Back seal test	2.2	
	Gas test	0.6	
Max working temperature		$\leq 425^{\circ}\text{C}$	
Applicable Medium: General oil, gas & water			

Ordering Information

VL - S - GL - F - 150 - 16
 I II III IV V VI

I Type of Item

VL Low Pressure Valves

II Material Grade

S	SS316, CF8M	CI	Cast Iron
FS	Forged Steel	CS	Cast Steel
B	Brass		

III Item

GA	Gate Valve	B1	1 PC Ball Valve
GL	Globe Valve	B2	2 PC Ball Valve
YS	Y-Strainer	B3	3 PC Ball Valve
SC	Swing Check Valve	BL	3 Way Ball Valve L Port
VC	Vertical Check Valve	BT	3 Way Ball Valve T Port
WC	Wafer Check Valve	BMF	Male x Female Mini Ball Valve
DD	Dual Disk	BU	Butterfly Valve

IV Connection Type

SW	S/W	G	BSPP
BW	B/W	N	NPT
R	BSPT	F	Flange End
W	Wafer	L	Lug

V Pressure

200	200 PSI	2000	2000 PSI
300	300 PSI	150	ANSI 150# Flange Standard
600	600 PSI	10K	JIS 10K Flange Standard
800	800 PSI	PN16	PN 16 Flange Standard
1000	1000 PSI		

For Inch OD & Inch NB Sizes
VI Size

Size	1/8"	1/4"	5/16"	3/8"	1/2"	5/8"	3/4"	1"
Code	02	04	05	06	08	10	12	16
Size	1 1/4"	1 1/2"	2"	2 1/2"	3"	4"	5"	6"
Code	20	24	32	40	48	64	80	96

VII Coating

(None) No Additional Coating
 NI Nickel Plating

Dimension List
DN25 – DN40

NPS	Part No	Q	D	D1	D2	L	W	H	B	f	n-Øz	Weight (Kg)
1"	VL-S-GL-F-150-16	18	108	79	51	127	125	203	14	1.3	4-Ø16	5.22
1 1/4"	VL-S-GL-F-150-20	23	117	89	63.5	140	160	224	16	1.3	4-Ø16	7.91
1 1/2"	VL-S-GL-F-150-24	30	127	98.5	75	165	160	260	17.5	1.3	4-Ø16	10.00

DN50 – DN100

NPS	Part No	d	D	D1	D2	C	f	L	n-d1	Weight (Kg)
2"	VL-S-GL-F-150-32	51	152	120.7	92.1	14.3	2	203	4-Ø19	13.00
2-1/2"	VL-S-GL-F-150-40	65	180	139.7	104.8	15.9	2	216	4-Ø19	17.75
3"	VL-S-GL-F-150-48	76	190	152.4	127	17.5	2	241	4-Ø19	20.75
4"	VL-S-GL-F-150-64	102	230	190.5	157.2	22.3	2	292	8-Ø19	33.15

Part Number Reference

Part No	Description
VL-S-GL-F-150-16	1" 150# SS316 FLANGE END GLOBE VALVE RF, RISING STEM, HANDWHEEL OPERATED
VL-S-GL-F-150-20	1 1/4" 150# SS316 FLANGE END GLOBE VALVE RF, RISING STEM, HANDWHEEL OPERATED
VL-S-GL-F-150-24	1 1/2" 150# SS316 FLANGE END GLOBE VALVE RF, RISING STEM, HANDWHEEL OPERATED
VL-S-GL-F-150-32	2" 150# SS316 FLANGE END GLOBE VALVE RISING STEM, HANDWHEEL OPERATED
VL-S-GL-F-150-40	2 1/2" 150# SS316 FLANGE END GLOBE VALVE RISING STEM, HANDWHEEL OPERATED
VL-S-GL-F-150-48	3" 150# SS316 FLANGE END GLOBE VALVE RISING STEM, HANDWHEEL OPERATED
VL-S-GL-F-150-64	4" 150# SS316 FLANGE END GLOBE VALVE RISING STEM, HANDWHEEL OPERATED

Chuan Kok Hardware & Machinery Pte Ltd

Address : 1783 Geylang Bahru, #01-02, Singapore 339708
Telephone Number : +65 6294 2566
Email Address : info@chuankok.com
Website : www.chuankok.com
Business Registration Number : 198201577Z
Country of Registration : Singapore

Conditions of Use of Catalogue:

The information in the catalogue are not binding and in order to improve distribution, Chuan Kok Hardware & Machinery Pte Ltd reserves the right to make any change including size and pressure ratings considered necessary at any time and without prior notice. According to the copyright and the civil law, any reproduction (also partial) of figures and texts of this catalogue by means of electronic, mechanical, photocopies, microfilms, recordings or other is forbidden without Chuan Kok Hardware & Machinery Pte Ltd's authorization.
Catalogue Version: 2021

