

GATE VALVES

ANSI 150# Cast Iron Gate Valves



ANSI 150# Cast Iron Flange End Gate Valves

Features

- ANSI 150# Flange Connection
- Size: 2" – 6" (DN50 – DN150)
- Valve Body Material: Cast Iron
- Working Pressure: 150#
- Applicable Medium: General oil, gas and water applications
- Temperature Range: ≤ 205°C



Material List

No.	Part Name	Material
1	Body	A126 B Cast Iron
2	Wedge	A126 B Cast Iron
3	Stem	A276 SS304
4	Bolts	A29 1035
5	Nuts	A29 1025
6	Gasket	SS304 + Graphite
7	Bonnet	A126 B Cast Iron
8	Packing	Flexible Graphite
9	Pin	A29 1045
10	Packing Gland	A276 SS304
11	Gland Flange	A126 B Cast Iron
12	Eye Bolts	A29 1035
13	Nuts	A29 1025
14	Stem Nut	A276 SUS410
15	Cover	A29 1025
16	Handwheel	A47 32510 Malleable Iron
17	Nut	A29 1025

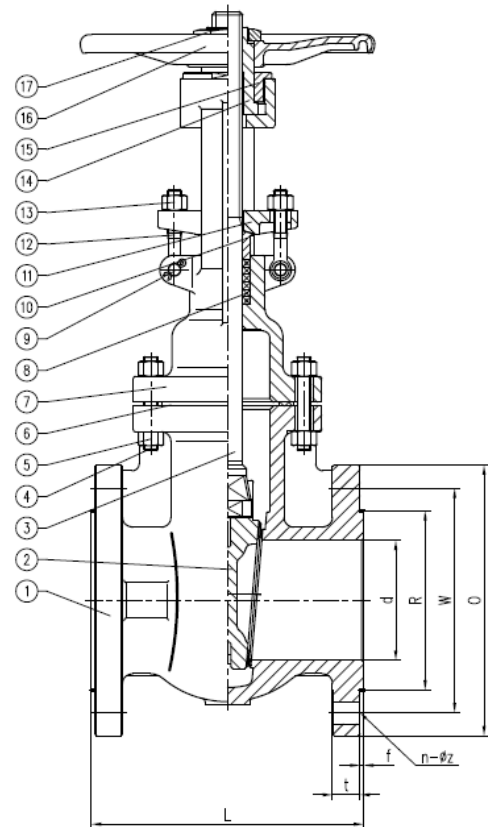

Pressure Test	Class 150	
Hydraulic body test pressure	2.06	MPa
Seal test pressure	1.57	
Hermetical Sealing Test	0.6	
Applicable Medium: General oil, gas & Water		

Ordering Information

VL - CI - GA - F - 150 - 32
 I - II - III - IV - V - VI

I Type of Item

VL Low Pressure Valves

II Material Grade

S	SS316, CF8M	CI	Cast Iron
FS	Forged Steel	CS	Cast Steel
B	Brass		

III Item

GA	Gate Valve	B1	1 PC Ball Valve
GL	Globe Valve	B2	2 PC Ball Valve
YS	Y-Strainer	B3	3 PC Ball Valve
SC	Swing Check Valve	BL	3 Way Ball Valve L Port
VC	Vertical Check Valve	BT	3 Way Ball Valve T Port
WC	Wafer Check Valve	BMF	Male x Female Mini Ball Valve
DD	Dual Disk	BU	Butterfly Valve

IV Connection Type

SW	S/W	G	BSPP
BW	B/W	N	NPT
R	BSPT	F	Flange End
W	Wafer	L	Lug

V Pressure

200	200 PSI	2000	2000 PSI
300	300 PSI	150	ANSI 150# Flange Standard
600	600 PSI	10K	JIS 10K Flange Standard
800	800 PSI	PN16	PN 16 Flange Standard
1000	1000 PSI		

For Inch OD & Inch NB Sizes
VI Size

Size	1/8"	1/4"	5/16"	3/8"	1/2"	5/8"	3/4"	1"
Code	02	04	05	06	08	10	12	16
Size	1 1/4"	1 1/2"	2"	2 1/2"	3"	4"	5"	6"
Code	20	24	32	40	48	64	80	96

VII Coating

(None)	No Additional Coating
NI	Nickel Plating

Dimension List

NPS	Part No	d	L	O	W	R	n – Øz	t	f	Weight (Kg)
2"	VL-CI-GA-F-150-32	50	178	152	120	92.1	4-Ø19	15.5	2	14.80
2-1/2"	VL-CI-GA-F-150-40	65	190	178	139	104.8	4-Ø19	16.6	2	20.10
3"	VL-CI-GA-F-150-48	80	204	190	150	127	4-Ø19	18	2	34.00
4"	VL-CI-GA-F-150-64	100	229	227	190	157.2	8-Ø19	22.5	2	39.00
5"	VL-CI-GA-F-150-80	125	254	254	216	-	8-Ø22	23.9	2	50.30
6"	VL-CI-GA-F-150-96	150	270	279	241.5	-	8-Ø22	25.4	2	61.15

Part Number Reference

Part No	Description
VL-CI-GA-F-150-32	2" 150# CI FLANGE END GATE VALVE RF, RISING STEM
VL-CI-GA-F-150-40	2 1/2" 150# CI FLANGE END GATE VALVE RF, RISING STEM
VL-CI-GA-F-150-48	3" 150# CI FLANGE END GATE VALVE RF, RISING STEM
VL-CI-GA-F-150-64	4" 150# CI FLANGE END GATE VALVE RF, RISING STEM
VL-CI-GA-F-150-80	5" 150# CI FLANGE END GATE VALVE RF, RISING STEM, SS304 TRIM
VL-CI-GA-F-150-96	6" 150# CI FLANGE END GATE VALVE RF, RISING STEM, SS304 TRIM

Chuan Kok Hardware & Machinery Pte Ltd

Address : 1783 Geylang Bahru, #01-02, Singapore 339708
Telephone Number : +65 6294 2566
Email Address : info@chuankok.com
Website : www.chuankok.com
Business Registration Number : 198201577Z
Country of Registration : Singapore

Conditions of Use of Catalogue:

The information in the catalogue are not binding and in order to improve distribution, Chuan Kok Hardware & Machinery Pte Ltd reserves the right to make any change including size and pressure ratings considered necessary at any time and without prior notice. According to the copyright and the civil law, any reproduction (also partial) of figures and texts of this catalogue by means of electronic, mechanical, photocopies, microfilms, recordings or other is forbidden without Chuan Kok Hardware & Machinery Pte Ltd's authorization.
Catalogue Version: 2021

