



THREADED END SS316 GATE VALVES (800 PSI)

Literature





Figure 1 Threaded End SS316 Gate Valve (800 PSI)

Introduction:

Gate valve is a valve that is used to allow fluids to flow through or stop the fluids from flowing through the valve. This can be operated by lift up or lift down the disc. It is designed and manufactured according to ASME B16.34/API 602 standard. It also went through the inspection and testing according to API 598.

Material and Design:

Gate valve is available in forged steel A105 or stainless steel SS316 material. For stainless steel SS316 material, there are 2 available designs which are screw-in bonnet type and bolted bonnet type.

While for forged steel A105 material, the design is available in bolted bonnet type only. For screw-in bonnet type design, a bonnet is screwed into the valve body to hold the internal parts that are put into the valve body, thus offering a pressure tight seal between the bonnet and valve body. Bolted bonnet design comes with a thicker cover that requires bolts and nuts to tighten with the valve body. This design is normally used for high pressure applications. The handle of both designs is designed to be wheel shaped.

Gate valve also can be available in 2 designs, rising stem design and non-rising stem design. For rising stem design, the stem will rise when the wheel handle is rotated to open position and lower when the wheel handle is rotated to close position. By looking at the amount of stem exposed, we can easily tell if the valve is in an open position or close position. However for non-rising stem design, the valve is in open position when the handle is rotated to the open position as far as possible and in closed position when the handle is rotated to close position as far as possible. Non-rising stem design gate valves are suitable to install on hydraulic systems that have limited space for the stem to raise in full, for example, underground pipe systems.

Size and Pressure Rating:

The size of the gate valve ranges from 1/2" to 2". For SS316 material, the working pressure is available in 200 PSI or 800 PSI. While for A105 material, the working pressure is only available in 800 PSI.

Connection Type:

For SS316 gate valve, it is only available in NPT (National Pipe Thread) female thread or BSPP (British Standard Pipe Parallel) female thread. For A105 gate valve, it is available in NPT female thread or Socket Weld connection. For the female thread gate valve, it needs a male thread of the same connection end to screw in to the gate valve. For socket weld connection, it needs a plain end pipe to connect.

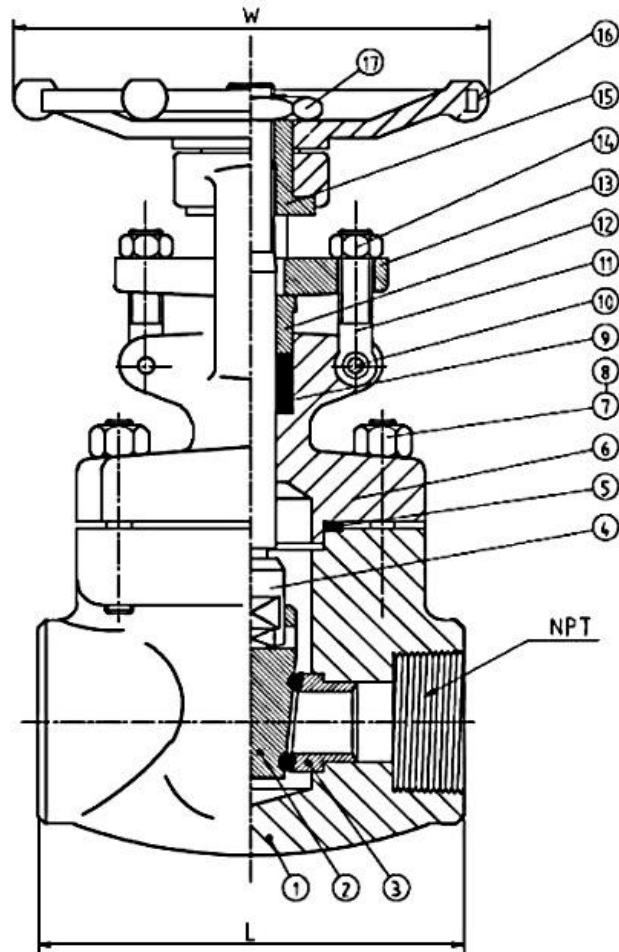

Figure 2 Threaded End SS316 Gate Valve (800 PSI)

Threaded End SS316 Gate Valve (800 PSI) Drawing:

No	Part Name	Material
1	Body	F316
2	Wedge	316 + STL
3	Seat	316 + STL
4	Stem	316
5	Gasket	316 + Graphite
6	Bonnet	F316
7	Stud Bolt	SS304
8	Nut	SS304
9	Packing	Graphite
10	Pin	304

11	Gland Eyebolt	SS304
12	Gland	316
13	Gland Flange	F304
14	Hex Nut	SS304
15	Stem Nut	410
16	Handwheel	A197
17	Locking Nut	ASTM 1035

Main Technical Parameter:

Nominal Pressure	800 PSI
Strength Test	21.5 MPa
Sealing Test	15.5 MPa
Back Seat Test	15.5 MPa
Air Sealing Test	0.6 MPa
Max Working Pressure	≤ 200

Technical Specifications:

1. Basic design and manufacture according to API 602
2. Inspection and test for according to API 598
3. Connection screw for the valve according to ASME B1.20.1

Chuan Kok Hardware & Machinery Pte Ltd

Address: 1783 Geylang Bahru #01-02, Kallang Distripark Singapore 339708

Telephone Number: +65 6294 2566

Fax Number: +65 6295 7013

Email Address: info@chuankok.com

Website: www.chuankok.com

Business Registration Number: 198201577Z

Country of Registration: Singapore

Conditions of Use of Catalogue:

The information in the catalogue are not binding and in order to improve distribution, Chuan Kok Hardware & Machinery Pte Ltd reserves the right to make any change including size and pressure ratings considered necessary at any time and without prior notice.

According to the copyright and the civil law, any reproduction (also partial) of figures and texts of this catalogue by means of electronic, mechanical, photocopies, microfilms, recordings or other is forbidden without Chuan Kok Hardware & Machinery Pte Ltd's authorization.
Catalogue Version: 1020

Chuan Kok Hardware & Machinery Pte Ltd

Address : 1783 Geylang Bahru, #01-02, Singapore 339708
Telephone Number : +65 6294 2566
Email Address : info@chuankok.com
Website : www.chuankok.com
Business Registration Number : 198201577Z
Country of Registration : Singapore

Conditions of Use of Catalogue:

The information in the catalogue are not binding and in order to improve distribution, Chuan Kok Hardware & Machinery Pte Ltd reserves the right to make any change including size and pressure ratings considered necessary at any time and without prior notice. According to the copyright and the civil law, any reproduction (also partial) of figures and texts of this catalogue by means of electronic, mechanical, photocopies, microfilms, recordings or other is forbidden without Chuan Kok Hardware & Machinery Pte Ltd's authorization.
Catalogue Version: 2021

