



# JIS10K SS316 FLANGE END BALL VALVES

## Literature



### Introduction:



**Figure 1 JIS 10K SS316  
Flange End Ball Valves**

JIS 10K SS316 flange end ball valve is a JIS standard flange type ball valve that is used for shut off application in a pipeline. It is designed and manufactured according to JIS B2071. Inspection and testing had been carried out according to JIS B2003 standard.

It is a full bore type valve with quarter turn operation. The handle can be pivoted at 90 degree to turn the valve in open position or close position. The locking device is used to lock the handle in open or close position only.

With the ISO mounting pad on the valve body, the actuator can mount on it for alternate operation instead of handle operation. The both end connection is flange with JIS 10K standard. Bolts, nuts, and gaskets are required when connected between two flanges. JIS 10K flange end ball valve is available in stainless steel SS316 material with PTFE sealing.

### JIS 10K Flanged End Ball Valve Drawing:

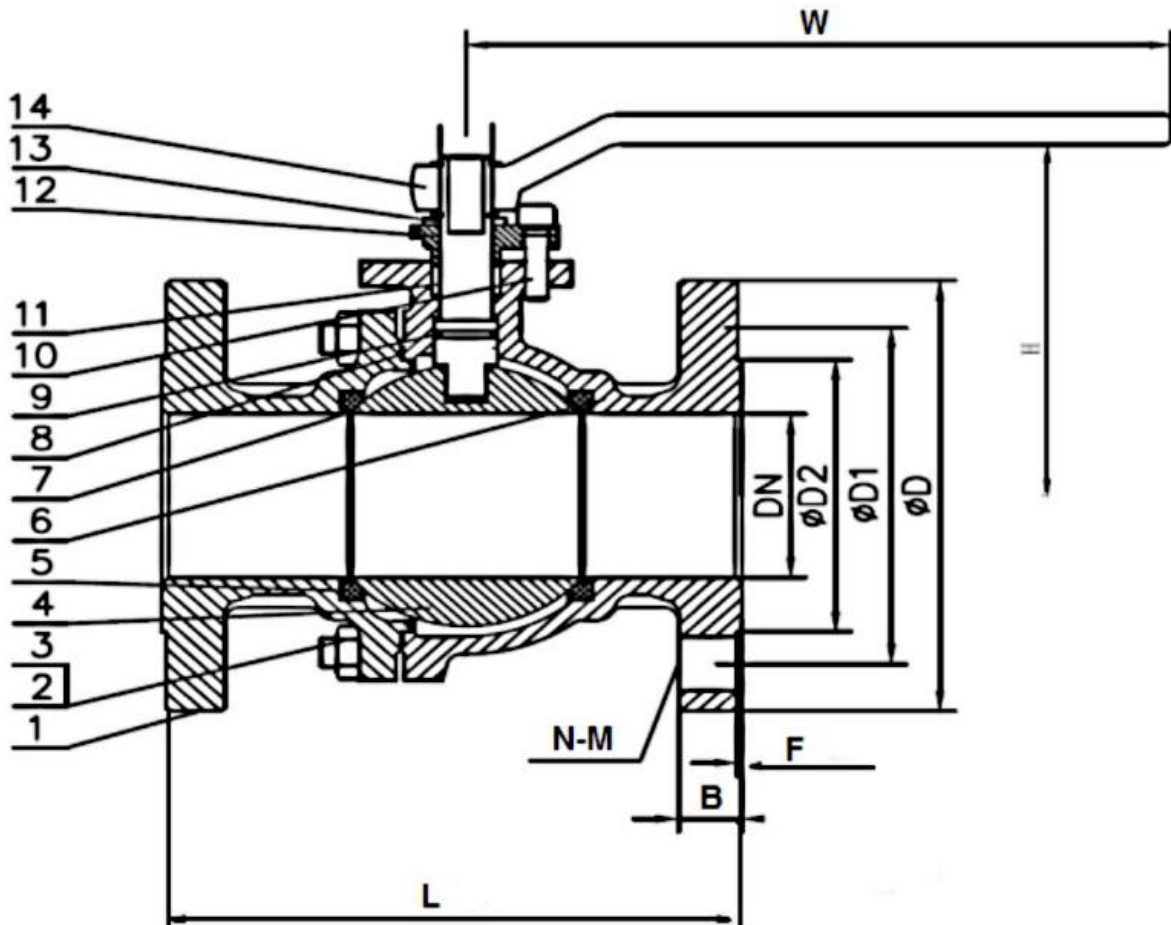

**Material:**

NO	PART NAME	MATERIAL
1	Left Body	SS316, CF8M
2	Stud Bolt	SS304
3	Nut	SS304
4	Ball	SS316
5	Seat	PTFE
6	Body	SS316, CF8M
7	Stem	SS316
8	Gasket	PTFE
9	O Ring	PTFE
10	Hexagon Screw	SS304
11	Packing	PTFE
12	Bonnet	SS316
13	Stop Block	SS304
14	Handle	SS201

**Main Technical Parameter:**

<b>Nominal Pressure</b>	JIS 10K
<b>Shell Test Pressure</b>	3.0 MPa
<b>Tightness Test</b>	2.2 MPa
<b>Gas-Tightness Test</b>	0.6 MPa
<b>Max working temperature</b>	-29°C to 150°C

**Technical Specifications:**

1. Basic design and manufacture according to JIS B2071
2. Face-to-face dimensions complied with JIS B2002
3. Flange ends complied with JIS B2220
4. Inspection and tested according to JIS B2003

## Chuan Kok Hardware & Machinery Pte Ltd

Address : 1783 Geylang Bahru, #01-02, Singapore 339708  
Telephone Number : +65 6294 2566  
Email Address : [info@chuankok.com](mailto:info@chuankok.com)  
Website : [www.chuankok.com](http://www.chuankok.com)  
Business Registration Number : 198201577Z  
Country of Registration : Singapore

### Conditions of Use of Catalogue:

The information in the catalogue are not binding and in order to improve distribution, Chuan Kok Hardware & Machinery Pte Ltd reserves the right to make any change including size and pressure ratings considered necessary at any time and without prior notice.

According to the copyright and the civil law, any reproduction (also partial) of figures and texts of this catalogue by means of electronic, mechanical, photocopies, microfilms, recordings or other is forbidden without Chuan Kok Hardware & Machinery Pte Ltd's authorization.

Catalogue Version: 2021

