

# FLANGE END BALL VALVES

## JIS10K SS316 Flange End Ball Valves

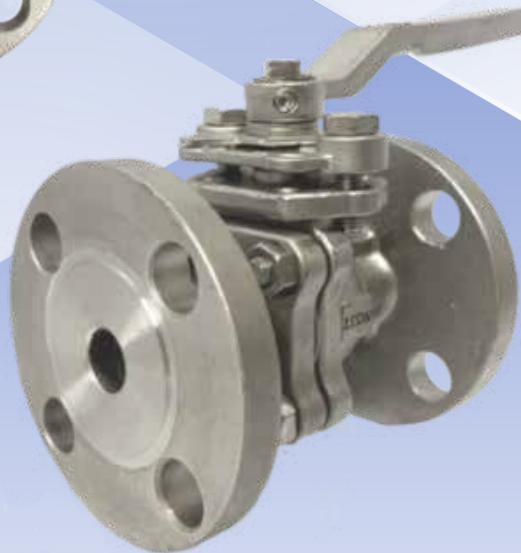

### JIS 10K Stainless Steel 2 Piece Flange Ball Valves

#### Features

- Full Bore
- JIS 10K Flange Connection
- Sizes: 1/2" - 6" (DN15 - DN150)
- Working Pressure: 10kgf/cm<sup>2</sup>
- Valve Body Material: Stainless Steel SS316
- Fire-safe Design According to API 607
- Applicable Medium: General Oil, Gas & Water Applications
- Blow-out Proof Stem Design
- Temperature: -29 Deg C to 150 Deg C

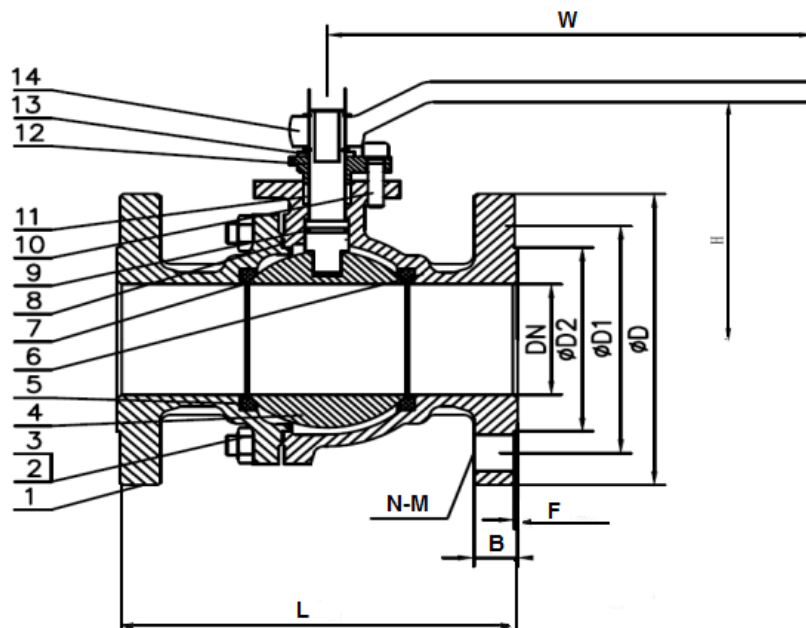

#### Technical Specifications

1. Basic design and manufacture according to JIS B2071
2. Face-to-face dimensions complied with JIS B2002
3. Flange ends complied with JIS B2220
4. Inspection and tested according to JIS B2003

Main Technical Parameter			
Normal pressure		10K	
Test pressure	Shell test pressure	3.0	MPa
	Tightness test	2.2	
	Gas-tightness test	0.6	
Max working temperature		-29 to 150	°C
Applicable medium: General oil, gas & water			

#### Material List

No.	Part Name	Material	No.	Part Name	Material
1	Left Body	SS316, CF8M	8	Gasket	PTFE
2	Stud Bolt	SS304	9	O-Ring	PTFE
3	Nut	SS304	10	Hexagon Screw	SS304
4	Ball	SS316	11	Packing	PTFE
5	Seat	PTFE	12	Bonnet	SS316
6	Body	SS316, CF8M	13	Stop Block	SS304
7	Stem	SS316	14	Handle	SS201

**Ordering Information**

VL - S - B2 - F - 10K - 08  
 I II III IV V VI

**I Type of Item**

VL Low Pressure Valves

**II Material Grade**

S	SS316, CF8M	CI	Cast Iron
FS	Forged Steel	CS	Cast Steel
B	Brass		

**III Item**

GA	Gate Valve	B1	1 PC Ball Valve
GL	Globe Valve	B2	2 PC Ball Valve
YS	Y-Strainer	B3	3 PC Ball Valve
SC	Swing Check Valve	BL	3 Way Ball Valve L Port
VC	Vertical Check Valve	BT	3 Way Ball Valve T Port
WC	Wafer Check Valve	BMF	Male x Female Mini Ball Valve
DD	Dual Disk	BU	Butterfly Valve

**IV Connection Type**

SW	S/W	G	BSPP
BW	B/W	N	NPT
R	BSPT	F	Flange End
W	Wafer	L	Lug

**V Pressure**

200	200 PSI	2000	2000 PSI
300	300 PSI	150	ANSI 150# Flange Standard
600	600 PSI	10K	JIS 10K Flange Standard
800	800 PSI	PN16	PN 16 Flange Standard
1000	1000 PSI		

**For Inch OD & Inch NB Sizes**
**VI Size**

Size	1/8"	1/4"	5/16"	3/8"	1/2"	5/8"	3/4"	1"
Code	02	04	05	06	08	10	12	16
Size	1 1/4"	1 1/2"	2"	2 1/2"	3"	4"	5"	6"
Code	20	24	32	40	48	64	80	96

**VII Coating**

(None)	No Additional Coating
NI	Nickel Plating

**Dimension List**

NPS (DN)	Connection	Impa Code	Part No	D	D1	D2	B	L	H	W	N- M	F	Weight (Kg)
1/2"	Flange End	-	VL-S-B2-F-10K-08	90	70	51	12	108	73	130	4-14	1.6	1.57
3/4"	Flange End	-	VL-S-B2-F-10K-12	100	75	56	14	117	76	130	4-14	1.6	-
1"	Flange End	-	VL-S-B2-F-10K-16	125	90	67	14	127	86	160	4-18	1.6	4.24
1 1/4"	Flange End	-	VL-S-B2-F-10K-20	135	100	76	16	140	91	160	4-18	1.6	3.33
1 1/2"	Flange End	-	VL-S-B2-F-10K-24	140	105	81	16	165	119	200	4-18	1.6	5.22
2"	Flange End	-	VL-S-B2-F-10K-32	155	120	96	16	178	127	200	4-18	1.6	7.86
2 1/2"	Flange End	-	VL-S-B2-F-10K-40	175	140	116	18	190	136	200	8-18	1.6	10.38
3"	Flange End	-	VL-S-B2-F-10K-48	185	150	126	18	203	164	325	8-18	1.6	15.55
4"	Flange End	-	VL-S-B2-F-10K-64	210	175	151	18	229	218	325	8-22	1.6	24.00
5"	Flange End	-	VL-S-B2-F-10K-80	254	215	180	18	355	-	-	8-23	1.6	41.20
6"	Flange End	-	VL-S-B2-F-10K-96	278	244	215	22	390	-	-	8-23	2	59.40

**Part Number Reference**

Impa Code	Part No	Description
-	VL-S-B2-F-10K-08	1/2"JIS10K SS316 FLANGE END BALL VALVE WITH ISO MOUNTING PAD, FIRE SAFE DESIGN
-	VL-S-B2-F-10K-12	3/4"JIS10K SS316 FLANGE END BALL VALVE WITH ISO MOUNTING PAD, FIRE SAFE DESIGN
-	VL-S-B2-F-10K-16	1"JIS10K SS316 FLANGE END BALL VALVE WITH ISO MOUNTING PAD, FIRE SAFE DESIGN
-	VL-S-B2-F-10K-20	1 1/4"JIS10K SS316 FLANGE END BALL VALVE WITH ISO MOUNTING PAD, FIRE SAFE DESIGN
-	VL-S-B2-F-10K-24	1 1/2"JIS10K SS316 FLANGE END BALL VALVE WITH ISO MOUNTING PAD, FIRE SAFE DESIGN
-	VL-S-B2-F-10K-32	2"JIS10K SS316 FLANGE END BALL VALVE WITH ISO MOUNTING PAD, FIRE SAFE DESIGN
-	VL-S-B2-F-10K-40	2 1/2"JIS10K SS316 FLANGE END BALL VALVE WITH ISO MOUNTING PAD, FIRE SAFE DESIGN
-	VL-S-B2-F-10K-48	3"JIS10K SS316 FLANGE END BALL VALVE WITH ISO MOUNTING PAD, FIRE SAFE DESIGN
-	VL-S-B2-F-10K-64	4"JIS10K SS316 FLANGE END BALL VALVE WITH ISO MOUNTING PAD, FIRE SAFE DESIGN
-	VL-S-B2-F-10K-80	5"JIS10K SS316 FLANGE END BALL VALVE WITH ISO MOUNTING PAD, FIRE SAFE DESIGN
-	VL-S-B2-F-10K-96	6"JIS10K SS316 FLANGE END BALL VALVE WITH ISO MOUNTING PAD, FIRE SAFE DESIGN

## Chuan Kok Hardware & Machinery Pte Ltd

Address : 1783 Geylang Bahru, #01-02, Singapore 339708  
Telephone Number : +65 6294 2566  
Email Address : [info@chuankok.com](mailto:info@chuankok.com)  
Website : [www.chuankok.com](http://www.chuankok.com)  
Business Registration Number : 198201577Z  
Country of Registration : Singapore

### Conditions of Use of Catalogue:

The information in the catalogue are not binding and in order to improve distribution, Chuan Kok Hardware & Machinery Pte Ltd reserves the right to make any change including size and pressure ratings considered necessary at any time and without prior notice.

According to the copyright and the civil law, any reproduction (also partial) of figures and texts of this catalogue by means of electronic, mechanical, photocopies, microfilms, recordings or other is forbidden without Chuan Kok Hardware & Machinery Pte Ltd's authorization.

Catalogue Version: 2021

