



ANSI 150# SS316 FLANGE END BALL VALVES

Literature



Introduction:

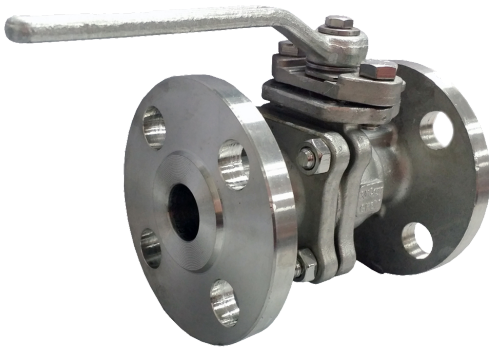

Figure 1 ANSI 150# SS316 Flange End Ball Valve

Flange end ball valve is suitable for shut off application in pipework. It is a full bore type ball valve with quarter turn operation. The handle can be pivoted at 90 degrees to open or close the valve. The locking device is to lock the handle in one position only, either in open position or close position.

The ISO mounting pad on the valve body allows the user to mount actuators on it instead of using a handle to control the valve. The both end of ball valve is come with ANSI 150#/300# flange. Accessories such as gasket, bolts and nuts are used to connect between two flanges.

It is designed and manufactured according to ANSI B16.34 standard. ANSI flange end ball valve will be inspected and tested according to API 598 standard. The number of bolt holes on the flange depends on the valve sizes, either 4 or 8 bolt holes. ANSI flange end ball valve is available in stainless steel SS316 material with PTFE seat sealing.

ANSI 150# SS316 Flange End Ball Valve Drawing:

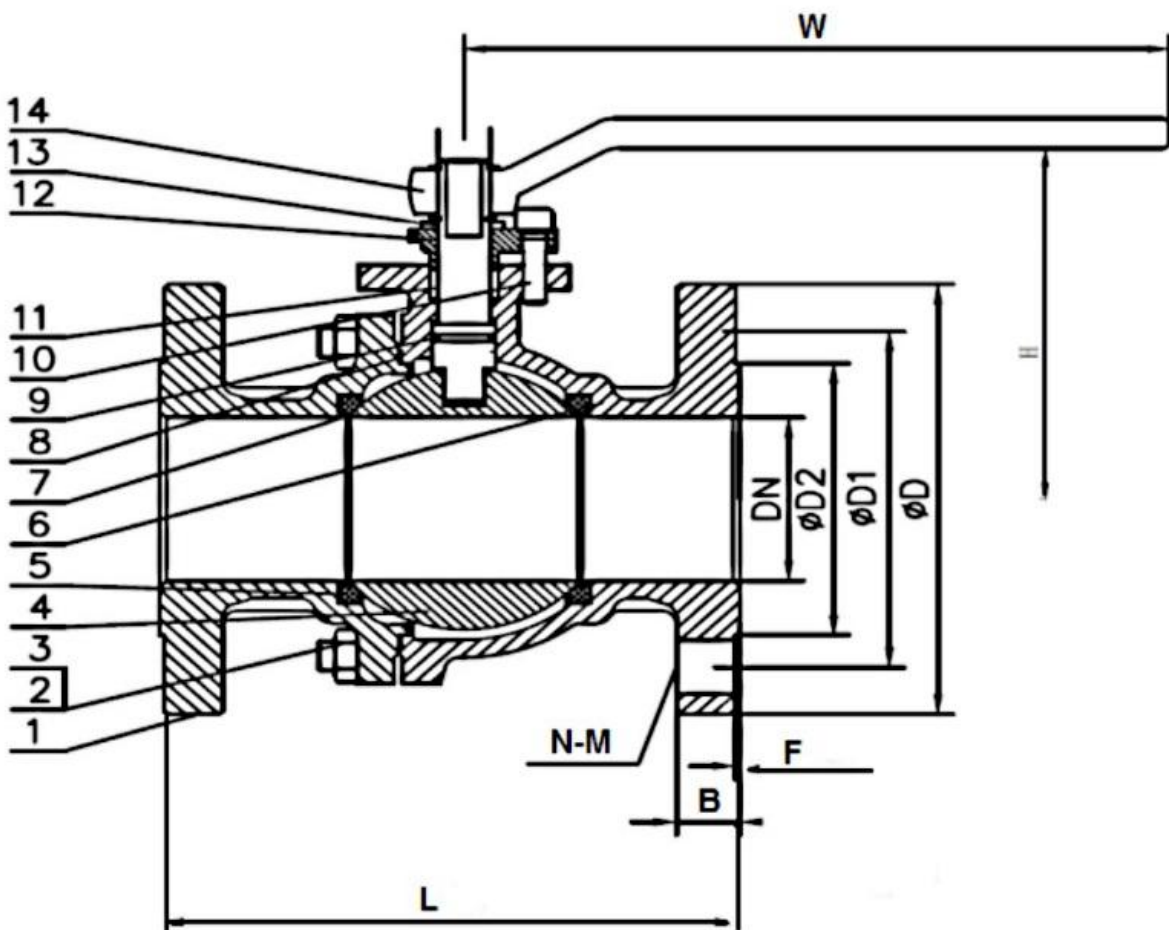

Material:

NO	PART NAME	MATERIAL
1	Left Body	SS316, CF8M
2	Stud Bolt	SS304
3	Nut	SS304
4	Ball	SS316
5	Seat	PTFE
6	Body	SS316, CF8M
7	Stem	SS316
8	Gasket	PTFE
9	O Ring	PTFE
10	Hexagon Screw	SS304
11	Packing	PTFE
12	Bonnet	SS316
13	Stop Block	SS304
14	Handle	SS201

Main Technical Parameter for ANSI 150#:

Nominal Pressure	CLASS 150
Shell Test Pressure	2.4 MPa
Tightness Test	1.8 MPa
Gas-Tightness Test	0.6 MPa
Max working temperature	-29°C to 150°C

Technical Specifications for ANSI 150#:

1. Basic design and manufacture according to ANSI B16.34
2. Face-to-face dimensions complies with GB/T12221
3. Flange ends complied with GB/T9113.1
4. Inspection and tested according to API598

Chuan Kok Hardware & Machinery Pte Ltd

Address : 1783 Geylang Bahru, #01-02, Singapore 339708
Telephone Number : +65 6294 2566
Email Address : info@chuankok.com
Website : www.chuankok.com
Business Registration Number : 198201577Z
Country of Registration : Singapore

Conditions of Use of Catalogue:

The information in the catalogue are not binding and in order to improve distribution, Chuan Kok Hardware & Machinery Pte Ltd reserves the right to make any change including size and pressure ratings considered necessary at any time and without prior notice. According to the copyright and the civil law, any reproduction (also partial) of figures and texts of this catalogue by means of electronic, mechanical, photocopies, microfilms, recordings or other is forbidden without Chuan Kok Hardware & Machinery Pte Ltd's authorization.
Catalogue Version: 2021

