

LOW PRESSURE BALL VALVES

2 PC Ball Valves



2 Piece Ball Valves

Features

- 2 PC Body Design
- Full Bore, Quarter Turn Operation
- Sizes: 1/4" – 4" (DN8 – DN100)
- Working Pressure: 1000 WOG / 2000 WOG
- Threaded End: BSPP, NPT
- Applicable Medium: General Oil, Gas & Water Applications
- Blow-out Proof Stem Design
- Temperature: -20 Deg C to 120 Deg C

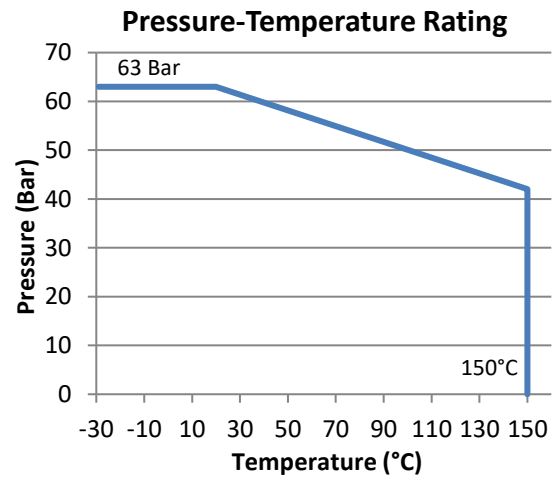
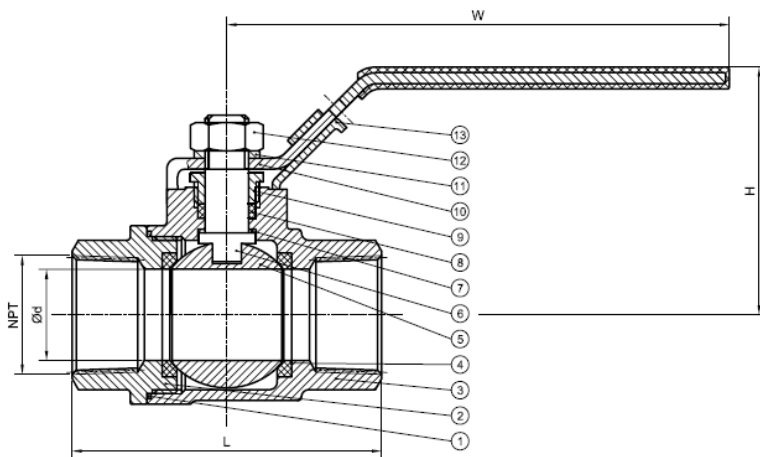

Material List

No.	Part Name	Material	No.	Part Name	Material
1	Gasket	PTFE	8	Stem Packing	PTFE
2	Body Connector	CF8M	9	Gland	AISI 304
3	Body	CF8M	10	Handle	AISI 304
4	Seat Ring	PTFE	11	Wrench Washer	AISI 304
5	Ball	CF8M	12	Handle Nut	AISI 304
6	Stem	AISI 316	13	Locking Device	AISI 304
7	Thrust Washer	PTFE			

Ordering Information

VL - S - B2 - G - 1000 - 08
 I II III IV V VI

I Type of Item
 VL Low Pressure Valves

II Material Grade

S	SS316, CF8M	CI	Cast Iron
FS	Forged Steel	CS	Cast Steel
B	Brass		

III Item

GA	Gate Valve	B1	1 PC Ball Valve
GL	Globe Valve	B2	2 PC Ball Valve
YS	Y-Strainer	B3	3 PC Ball Valve
SC	Swing Check Valve	BL	3 Way Ball Valve L Port
VC	Vertical Check Valve	BT	3 Way Ball Valve T Port
WC	Wafer Check Valve	BMF	Male x Female Mini Ball Valve
DD	Dual Disk	BU	Butterfly Valve

IV Connection Type

SW	S/W	G	BSPP
BW	B/W	N	NPT
R	BSPT	F	Flange End
W	Wafer	L	Lug

V Pressure

200	200 PSI	2000	2000 PSI
300	300 PSI	150	ANSI 150# Flange Standard
600	600 PSI	10K	JIS 10K Flange Standard
800	800 PSI	PN16	PN 16 Flange Standard
1000	1000 PSI		

For Inch OD & Inch NB Sizes

VI	Size							
Size	1/8"	1/4"	5/16"	3/8"	1/2"	5/8"	3/4"	1"
Code	02	04	05	06	08	10	12	16
Size	1 1/4"	1 1/2"	2"	2 1/2"	3"	4"	5"	6"
Code	20	24	32	40	48	64	80	96

VII Coating

(None)	No Additional Coating
NI	Nickel Plating

Dimension List (1000 WOG)

NPS	Connection	Impa Code	Part No	d	L	H	W	Weight (Kg)
1/4"	BSPP	75 66 65	VL-S-B2-G-1000-04	10	53	45	100	0.21
3/8"	BSPP	75 66 66	VL-S-B2-G-1000-06	12	53	45	100	0.25
1/2"	BSPP	75 66 67	VL-S-B2-G-1000-08	15	62	49	104	0.30
3/4"	BSPP	75 66 68	VL-S-B2-G-1000-12	20	70	55	118	0.51
1"	BSPP	75 66 69	VL-S-B2-G-1000-16	25	81	67	145	0.75
1 1/4"	BSPP	75 66 70	VL-S-B2-G-1000-20	32	95	70	145	1.48
1 1/2"	BSPP	75 66 71	VL-S-B2-G-1000-24	38	105	80	177	1.72
2"	BSPP	75 66 72	VL-S-B2-G-1000-32	50	117	92	177	3.08
2 1/2"	BSPP	75 66 73	VL-S-B2-G-1000-40	65	163	113	224	4.85
3"	BSPP	75 66 74	VL-S-B2-G-1000-48	80	190	127	242	7.53
4"	BSPP	-	VL-S-B2-G-1000-64	96	227	180	280	13.5
1/4"	NPT	75 65 89	VL-S-B2-N-1000-04	10	53	45	100	0.21
3/8"	NPT	75 65 90	VL-S-B2-N-1000-06	12	53	45	100	0.25
1/2"	NPT	75 65 91	VL-S-B2-N-1000-08	15	62	49	104	0.30
3/4"	NPT	75 65 92	VL-S-B2-N-1000-12	20	70	55	118	0.51
1"	NPT	75 65 93	VL-S-B2-N-1000-16	25	81	67	145	0.75
1 1/4"	NPT	75 65 94	VL-S-B2-N-1000-20	32	95	70	145	1.48
1 1/2"	NPT	75 65 95	VL-S-B2-N-1000-24	38	105	80	177	1.72
2"	NPT	75 65 96	VL-S-B2-N-1000-32	50	117	92	177	3.08
2 1/2"	NPT	75 65 97	VL-S-B2-N-1000-40	65	163	113	224	4.85
3"	NPT	75 65 98	VL-S-B2-N-1000-48	80	190	127	242	7.53
4"	NPT	-	VL-S-B2-N-1000-64	96	227	180	280	13.5

Part Number Reference (1000 WOG)

Impa Code	Part No	Description
75 66 65	VL-S-B2-G-1000-04	1/4"BSPP SS316 2 PC BALL VALVE (1000 WOG)
75 66 66	VL-S-B2-G-1000-06	3/8"BSPP SS316 2 PC BALL VALVE (1000 WOG)
75 66 67	VL-S-B2-G-1000-08	1/2"BSPP SS316 2 PC BALL VALVE (1000 WOG)
75 66 68	VL-S-B2-G-1000-12	3/4"BSPP SS316 2 PC BALL VALVE (1000 WOG)
75 66 69	VL-S-B2-G-1000-16	1"BSPP SS316 2 PC BALL VALVE (1000 WOG)
75 66 70	VL-S-B2-G-1000-20	1 1/4"BSPP SS316 2 PC BALL VALVE (1000 WOG)
75 66 71	VL-S-B2-G-1000-24	1 1/2"BSPP SS316 2 PC BALL VALVE (1000 WOG)
75 66 72	VL-S-B2-G-1000-32	2"BSPP SS316 2 PC BALL VALVE (1000 WOG)
75 66 73	VL-S-B2-G-1000-40	2 1/2"BSPP SS316 2 PC BALL VALVE (1000 WOG)
75 66 74	VL-S-B2-G-1000-48	3"BSPP SS316 2 PC BALL VALVE (1000 WOG)
-	VL-S-B2-G-1000-64	4"BSPP SS316 2 PC BALL VALVE (1000 WOG)
75 65 89	VL-S-B2-N-1000-04	1/4"NPT SS316 2 PC BALL VALVE (1000 WOG)
75 65 90	VL-S-B2-N-1000-06	3/8"NPT SS316 2 PC BALL VALVE (1000 WOG)
75 65 91	VL-S-B2-N-1000-08	1/2"NPT SS316 2 PC BALL VALVE (1000 WOG)
75 65 92	VL-S-B2-N-1000-12	3/4"NPT SS316 2 PC BALL VALVE (1000 WOG)
75 65 93	VL-S-B2-N-1000-16	1"NPT SS316 2 PC BALL VALVE (1000 WOG)
75 65 94	VL-S-B2-N-1000-20	1 1/4"NPT SS316 2 PC BALL VALVE (1000 WOG)
75 65 95	VL-S-B2-N-1000-24	1 1/2"NPT SS316 2 PC BALL VALVE (1000 WOG)
75 65 96	VL-S-B2-N-1000-32	2"NPT SS316 2 PC BALL VALVE (1000 WOG)
75 65 97	VL-S-B2-N-1000-40	2 1/2"NPT SS316 2 PC BALL VALVE (1000 WOG)
-	VL-S-B1-N-1000-48	3"NPT SS316 1 PC BALL VALVE (1000 WOG)
-	VL-S-B1-N-1000-64	4"NPT SS316 1 PC BALL VALVE (1000 WOG)

Dimension List (2000 WOG)

NPS	Connection	Impa Code	Part No	d	L	H	W	Weight (Kg)
1/4"	BSPP	75 66 65	VL-S-B2-G-2000-04	10	55	42	95	0.21
3/8"	BSPP	75 66 66	VL-S-B2-G-2000-06	10	55	42	95	0.25
1/2"	BSPP	75 66 67	VL-S-B2-G-2000-08	15	62	51	108	0.30
3/4"	BSPP	75 66 68	VL-S-B2-G-2000-12	20	72	58	115	0.51
1"	BSPP	75 66 69	VL-S-B2-G-2000-16	25	84	77	135	0.75
1 1/4"	BSPP	75 66 70	VL-S-B2-G-2000-20	32	97	83	150	1.48
1 1/2"	BSPP	75 66 71	VL-S-B2-G-2000-24	38	104	97	175	1.72
2"	BSPP	75 66 72	VL-S-B2-G-2000-32	49	120	106	190	3.08
2 1/2"	BSPP	75 66 73	VL-S-B2-G-2000-40	63	150	122	220	4.85
3"	BSPP	75 66 74	VL-S-B2-G-2000-48	80	164	140	250	7.53
1/4"	NPT	75 65 89	VL-S-B2-N-2000-04	10	55	42	95	0.21
3/8"	NPT	75 65 90	VL-S-B2-N-2000-06	10	55	42	95	0.25
1/2"	NPT	75 65 91	VL-S-B2-N-2000-08	15	62	51	108	0.30
3/4"	NPT	75 65 92	VL-S-B2-N-2000-12	20	72	58	115	0.51
1"	NPT	75 65 93	VL-S-B2-N-2000-16	25	84	77	135	0.75
1 1/4"	NPT	75 65 94	VL-S-B2-N-2000-20	32	97	83	150	1.48
1 1/2"	NPT	75 65 95	VL-S-B2-N-2000-24	38	104	97	175	1.72
2"	NPT	75 65 96	VL-S-B2-N-2000-32	49	120	106	190	3.08
2 1/2"	NPT	75 65 97	VL-S-B2-N-2000-40	63	150	122	220	4.85
3"	NPT	75 65 98	VL-S-B2-N-2000-48	80	164	140	250	7.53

Part Number Reference (2000 WOG)

Impa Code	Part No	Description
75 66 65	VL-S-B2-G-2000-04	1/4"BSPP SS316 2 PC BALL VALVE (2000 WOG)
75 66 66	VL-S-B2-G-2000-06	3/8"BSPP SS316 2 PC BALL VALVE (2000 WOG)
75 66 67	VL-S-B2-G-2000-08	1/2"BSPP SS316 2 PC BALL VALVE (2000 WOG)
75 66 68	VL-S-B2-G-2000-12	3/4"BSPP SS316 2 PC BALL VALVE (2000 WOG)
75 66 69	VL-S-B2-G-2000-16	1"BSPP SS316 2 PC BALL VALVE (2000 WOG)
75 66 70	VL-S-B2-G-2000-20	1 1/4"BSPP SS316 2 PC BALL VALVE (2000 WOG)
75 66 71	VL-S-B2-G-2000-24	1 1/2"BSPP SS316 2 PC BALL VALVE (2000 WOG)
75 66 72	VL-S-B2-G-2000-32	2"BSPP SS316 2 PC BALL VALVE (2000 WOG)
75 66 73	VL-S-B2-G-2000-40	2 1/2"BSPP SS316 2 PC BALL VALVE (2000 WOG)
75 66 74	VL-S-B2-G-2000-48	3"BSPP SS316 2 PC BALL VALVE (2000 WOG)
75 65 89	VL-S-B2-N-2000-04	1/4"NPT SS316 2 PC BALL VALVE (2000 WOG)
75 65 90	VL-S-B2-N-2000-06	3/8"NPT SS316 2 PC BALL VALVE (2000 WOG)
75 65 91	VL-S-B2-N-2000-08	1/2"NPT SS316 2 PC BALL VALVE (2000 WOG)
75 65 92	VL-S-B2-N-2000-12	3/4"NPT SS316 2 PC BALL VALVE (2000 WOG)
75 65 93	VL-S-B2-N-2000-16	1"NPT SS316 2 PC BALL VALVE (2000 WOG)
75 65 94	VL-S-B2-N-2000-20	1 1/4"NPT SS316 2 PC BALL VALVE (2000 WOG)
75 65 95	VL-S-B2-N-2000-24	1 1/2"NPT SS316 2 PC BALL VALVE (2000 WOG)
75 65 96	VL-S-B2-N-2000-32	2"NPT SS316 2 PC BALL VALVE (2000 WOG)
75 65 97	VL-S-B2-N-2000-40	2 1/2"NPT SS316 2 PC BALL VALVE (2000 WOG)
75 65 98	VL-S-B2-N-2000-48	3"NPT SS316 2 PC BALL VALVE (2000 WOG)

Chuan Kok Hardware & Machinery Pte Ltd

Address : 1783 Geylang Bahru, #01-02, Singapore 339708
Telephone Number : +65 6294 2566
Email Address : info@chuankok.com
Website : www.chuankok.com
Business Registration Number : 198201577Z
Country of Registration : Singapore

Conditions of Use of Catalogue:

The information in the catalogue are not binding and in order to improve distribution, Chuan Kok Hardware & Machinery Pte Ltd reserves the right to make any change including size and pressure ratings considered necessary at any time and without prior notice. According to the copyright and the civil law, any reproduction (also partial) of figures and texts of this catalogue by means of electronic, mechanical, photocopies, microfilms, recordings or other is forbidden without Chuan Kok Hardware & Machinery Pte Ltd's authorization.
Catalogue Version: 2021

