



ANSI 150# CAST IRON LUG TYPE BUTTERFLY VALVES

Literature



Introduction:



Figure 1 ANSI 150# Cast Iron
Lug Type Butterfly Valve

Butterfly valve is a quarter-turn valve that is used to start, stop, and regulate flow in a pipeline system. It has a disc which is mounted on a shaft. By turning the handle in quarter turn, the disc will turn to open position or close position. When the valve is turned to open position, the disc moves away from the seat and is parallel to the flow. In the close position, the disc is perpendicular to the flow and sealed by the seat. Partial rotation of the handle is applicable for throttle application. It is designed and manufactured according to API 609 standard. Inspection and testing had been carried out according to API 598 standard. Butterfly valve is widely installed on solid liquids applications such as oil and chemical, water supply, fire protection, and wastewater treatment at low pressure.

Material and Design:

Butterfly valve is available in cast iron material, which is relatively low cost with standard performance. A blue color external paint had been applied on the valve body to enhance the corrosion resistance. The seat is available in EPDM material which fits on the disk edge to provide sealing to any leakage.

Butterfly valves are available in wafer type or lug type design. For the wafer type butterfly valve, it is in short body length and flange hole outside of valve body. The design of lug type butterfly valve is similar to wafer type where it also has short body length, however it comes with threaded bolt hole outside of valve body. The number of threaded bolt holes is dependent on valve sizes, 4 hole option is available for sizes below 4" while 8 hole option is available for sizes above 4".

Size and Pressure Rating:

The available size for butterfly valves ranges from 1 1/2" to 6". It can withstand up to 150 PSI working pressure

Connection Type:

For the wafer type butterfly valve, it is installed between two flanges with long bolts crossed by and tightened with nuts. Lug type butterfly valves have threaded bolt holes outside the valve body. A number of bolts is connected to the two flanges by tightening bolts to each side of the threaded bolt hole with a butterfly valve placed at center.

Lug Type Butterfly Valve Drawing:

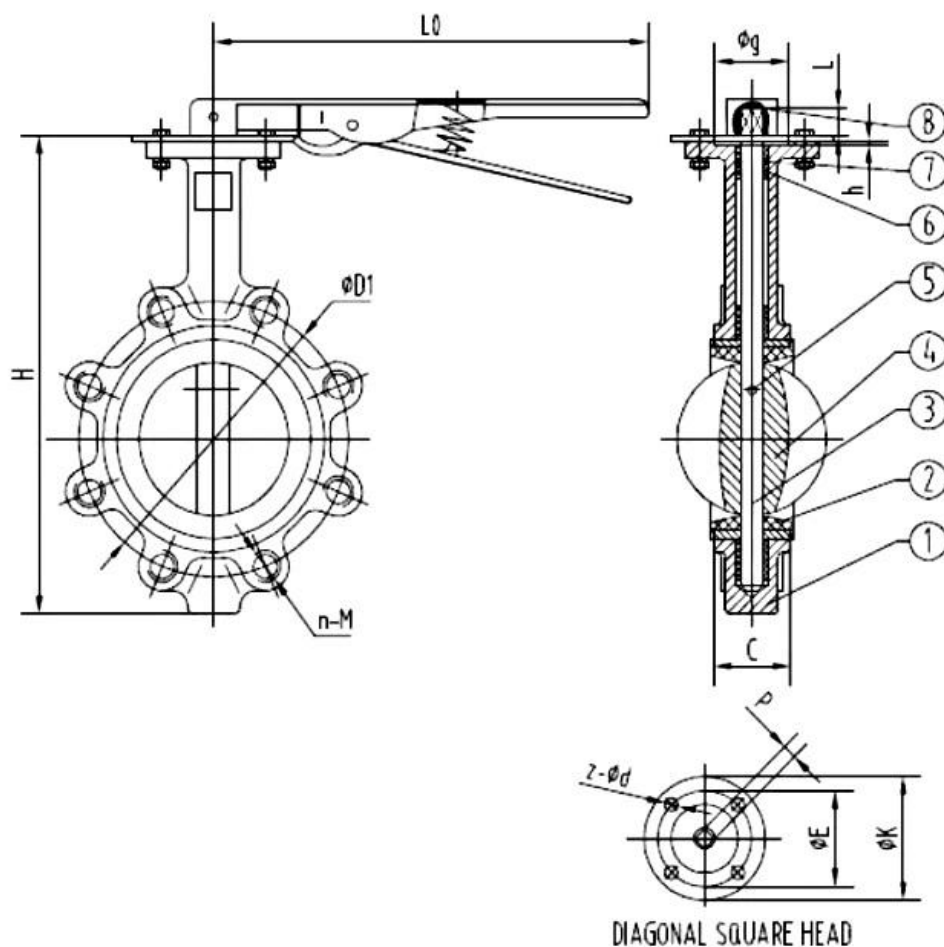

Material:

NO	PART NAME	MATERIAL
1	Body	Cast Iron
2	Seat	EPDM
3	Shaft	SS410
4	Disc	CF8
5	Pin	SS304
6	Bushing	Polymers
7	Oring	NBR
8	Handle Lever	Ductile Iron

Main Technical Parameter:

Normal Pressure	1.6 MPa
Shell Test Pressure	2.4 MPa
Sealing Test Pressure	1.76 MPa
Working Temperature	-30°C to 120°C

Technical Specifications:

1. Basic design and manufacture according to API 609
2. Face to face dimension: API609
3. Inspection and test: API 598

Chuan Kok Hardware & Machinery Pte Ltd

Address : 1783 Geylang Bahru, #01-02, Singapore 339708
Telephone Number : +65 6294 2566
Email Address : info@chuankok.com
Website : www.chuankok.com
Business Registration Number : 198201577Z
Country of Registration : Singapore

Conditions of Use of Catalogue:

The information in the catalogue are not binding and in order to improve distribution, Chuan Kok Hardware & Machinery Pte Ltd reserves the right to make any change including size and pressure ratings considered necessary at any time and without prior notice. According to the copyright and the civil law, any reproduction (also partial) of figures and texts of this catalogue by means of electronic, mechanical, photocopies, microfilms, recordings or other is forbidden without Chuan Kok Hardware & Machinery Pte Ltd's authorization.
Catalogue Version: 2021

