

# FLANGES

## Split Flanges



### Hydraulic SAE Split Flanges

**Specifications:**

SAE-J518/ISO 6162, Hydraulic flanged tube, pipe and hose connections, four-bolt split flange type

**Material Specifications:**

ST52.3  
 SS316

**Size Range:**

Code 61 (Series 3000): 3/8"NB – 5"NB  
 Code 62 (Series 6000): 3/8"NB – 3"NB



**Working Pressure:**

Code 61 (Series 3000): 34 – 345 Bar  
 Code 62 (Series 6000): 200 – 414 Bar

**Temperature:**

Carbon steel: -40°C - +120°C  
 Stainless steel: -60°C - +50°C  
 Working pressure for material stainless steel shall be reduced if exceed certain temperature:  
 40% above +50°C to < +100°C  
 11% above +100°C to < +200°C  
 20% above +200°C to < +250°C

**Orings:**

NBR (Standard), Viton (Optional)

**Flange Screws:**

Metric screws according to DIN 912-8.8 (Standard)  
 Metric screws according to DIN 912-10.9 (Optional)

**SAE Flange Recommended Torque Values**

**Code 61 (Series 3000)**

Flange Size	Recommended Torque Range N/m
1/2"	32
3/4"	70
1"	70
1 1/4"	70
1 1/2"	130
2"	130
2 1/2"	130
3"	295
3 1/2"	295
4"	295
5"	295

**Code 62 (Series 6000)**

Flange Size	Recommended Torque Range N/m (+10% -0)
1/2"	32
3/4"	70
1"	130
1 1/4"	130
1 1/2"	295
2"	550
2 1/2"	550
3"	650

**Index**

<b>Type</b>	<b>Page No.</b>
Cut Split Flanges	3
Uncut Split Flanges	4
Weld On Flange Head	5

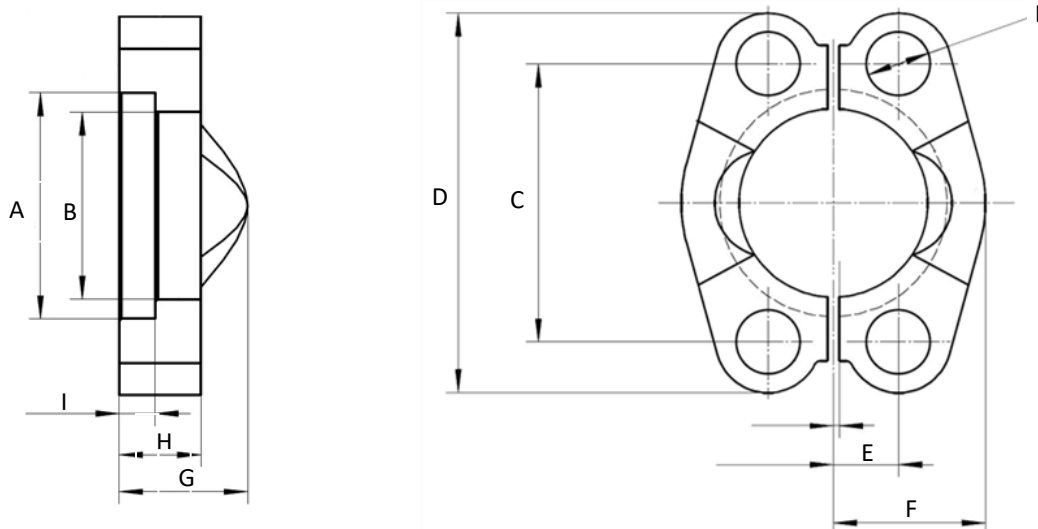
**CUT SPLIT FLANGES**

**Series 3000**

WP (Bar)	Size	Type	Dimensions									
			A	B	C	D	E	F	G	H	I	Screws / L
345	1/2"	AFS301	30.96	24.26	38.10	54	8.74	22.8	19	13	6.22	M8 x 30
345	3/4"	AFS302	38.89	32.13	47.63	65	11.13	25.9	22	14	6.22	M10 x 35
345	1"	AFS303	45.24	38.48	52.37	70	13.08	29.2	24	16	7.49	M10 x 35
276	1 1/4"	AFS304	51.59	43.69	58.72	79	15.09	36.3	22	14	7.49	M10 x 35
207	1 1/2"	AFS305	61.09	50.80	69.85	94	17.86	41.1	25	16	7.49	M12 x 35
207	2"	AFS306	72.24	62.74	77.77	102	21.44	48.2	26	16	9.02	M12 x 35
172	2 1/2"	AFS307	84.94	74.93	88.90	114	25.40	54.1	38	19	9.02	M12 x 40
138	3"	AFS308	102.39	90.93	106.38	135	30.96	65.3	41	22	9.02	M16 x 50
34	3 1/2"	AFS309	115.10	102.36	120.65	152	34.92	69.5	28	22	10.72	M16 x 50
34	4"	AFS310	127.79	115.06	130.18	162	38.88	76.0	35	25	10.72	M16 x 50
34	5"	AFS311	153.19	140.46	152.40	184	46.04	90.0	41	28	10.72	M16 x 50

**Series 6000**

WP (Bar)	Size	Type	Dimensions									
			A	B	C	D	E	F	G	H	I	Screws / L
414	1/2"	AFS601	32.54	24.64	40.49	56	9.12	23.6	22	16	7.24	M8 x 30
414	3/4"	AFS602	42.06	32.51	50.80	71	11.91	30.0	28	19	8.26	M10 x 35
414	1"	AFS603	48.41	38.86	57.15	81	13.89	34.8	33	24	9.02	M12 x 45
414	1 1/4"	AFS604	54.76	44.45	66.68	95	15.88	38.6	38	27	9.78	M14 x 45
414	1 1/2"	AFS605	64.29	51.56	79.38	113	18.26	47.5	43	30	12.07	M16 x 50
414	2"	AFS606	80.16	67.56	96.82	133	22.23	56.9	52	37	12.07	M20 x 70

**Designation for Order:**

Cut Split Flanges

ST52.3	AFS...
SS316	AFX...

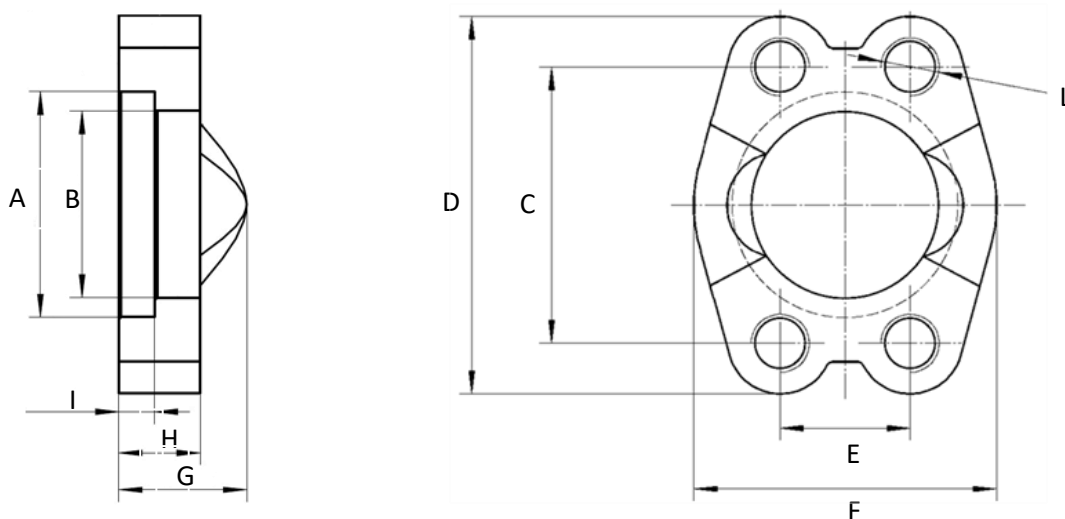
**UNCUT SPLIT FLANGES**

**Series 3000**

WP (Bar)	Size	Type	Dimensions									
			A	B	C	D	E	F	G	H	I	Screws / L
345	1/2"	AFSI301	30.96	24.26	38.10	54	17.48	45.6	19	13	6.22	M8 x 30
345	3/4"	AFSI302	38.89	32.13	47.63	65	22.23	51.8	22	14	6.22	M10 x 35
345	1"	AFSI303	45.24	38.48	52.37	70	26.19	58.4	24	16	7.49	M10 x 35
276	1 1/4"	AFSI304	51.59	43.69	58.72	79	30.18	72.6	22	14	7.49	M10 x 35
207	1 1/2"	AFSI305	61.09	50.80	69.85	94	35.71	82.2	25	16	7.49	M12 x 35
207	2"	AFSI306	72.24	62.74	77.77	102	42.88	96.4	26	16	9.02	M12 x 35
172	2 1/2"	AFSI307	84.94	74.93	88.90	114	50.80	108.2	38	19	9.02	M12 x 40
138	3"	AFSI308	102.39	90.93	106.38	135	61.93	130.6	41	22	9.02	M16 x 50
34	3 1/2"	AFSI309	115.10	102.36	120.65	152	69.85	139.0	28	22	10.72	M16 x 50
34	4"	AFSI310	127.79	115.06	130.18	162	77.77	152.0	35	25	10.72	M16 x 50
34	5"	AFSI311	153.19	140.46	152.40	184	92.08	180.0	41	28	10.72	M16 x 50

**Series 6000**

WP (Bar)	Size	Type	Dimensions									
			A	B	C	D	E	F	G	H	I	Screws / L
414	1/2"	AFSI601	32.54	24.64	40.49	56	18.24	47.2	22	16	7.24	M8 x 30
414	3/4"	AFSI602	42.06	32.51	50.80	71	23.80	60.0	28	19	8.26	M10 x 35
414	1"	AFSI603	48.41	38.86	57.15	81	27.76	69.6	33	24	9.02	M12 x 45
414	1 1/4"	AFSI604	54.76	44.45	66.68	95	31.75	77.2	38	27	9.78	M14 x 45
414	1 1/2"	AFSI605	64.29	51.56	79.38	113	36.50	95.0	43	30	12.07	M16 x 50
414	2"	AFSI606	80.16	67.56	96.82	133	44.45	113.8	52	37	12.07	M20 x 70

**Designation for Order:**

 Uncut Split Flanges  
 (Without bolt thread)

ST52.3	AFSI...
SS316	AFXI...

 Uncut Split Flanges  
 (With bolt thread)

ST52.3	GFSI...
SS316	GFXI...

**WELD ON FLANGE HEAD**

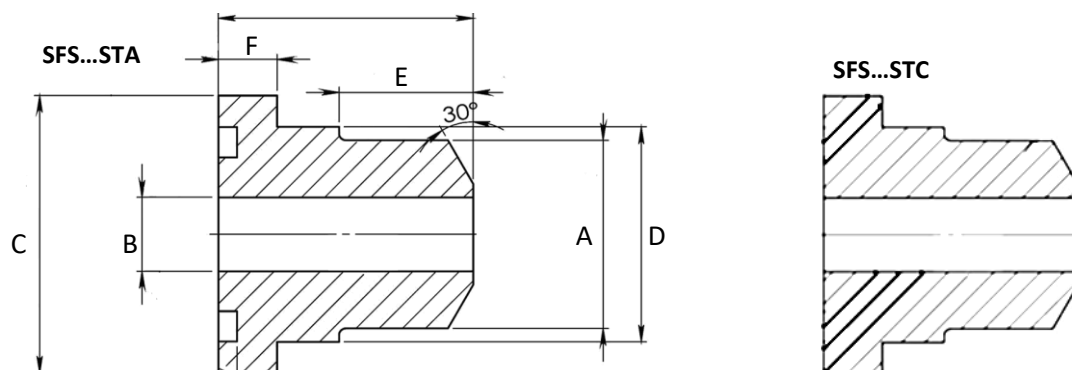

**Series 3000**

WP (Bar)	Size	Type	Dimensions					
			A	B	C	D	E	F
345	1/2"	SFS301STA21B6	21.5	6.3	30.2	24	41	6.73
345	3/4"	SFS302STA28B11	28.0	11.0	38.1	32	50	6.73
345	1"	SFS303STA34B15	34.0	15.2	44.4	38	50	8.00
276	1 1/4"	SFS304STA42B22	42.8	22.8	50.8	43	55	8.00
207	1 1/2"	SFS305STA50B28	50.0	28.0	60.3	50	57	8.00
207	2"	SFS306STA61B38	61.0	38.2	71.4	62	57	9.53
172	2 1/2"	SFS307STA74B54	74.0	54.0	84.1	74	58	9.53
138	3"	SFS308STA90B66	90.0	66.0	101.6	90	60	9.53
34	3 1/2"	SFS309STA102B76	102.0	76.0	114.3	102	80	11.20
34	4"	SFS311STA114B87	114.3	87.0	127.0	114.3	80	11.20
34	5"	SFS311STA139B107	139.7	107.0	152.4	139.7	80	11.20

**Series 6000**

WP (Bar)	Size	Type	Dimensions					
			A	B	C	D	E	F
414	1/2"	SFS601STA21B6	21.5	6.3	31.8	24	34	7.75
414	3/4"	SFS602STA28B11	28.0	11.0	41.3	32	38	8.76
414	1"	SFS603STA34B15	34.0	15.2	47.6	38	40	9.53
414	1 1/4"	SFS604STA42B22	42.8	22.8	54.0	44	45	10.29
414	1 1/2"	SFS605STA50B28	50.0	28.0	63.5	51	50	12.57
414	2"	SFS606STA61B38	61.0	38.2	79.4	67	58	12.57

**Designation for Order:**

Counter-Flanges  
 (Flat side)

ST52.3	SFS...STCA
SS316	SFX...STCA

Flanges  
 (Oring side)

ST52.3	SFS...STA
SS316	SFX...STA

## Chuan Kok Hardware & Machinery Pte Ltd

Address : 1783 Geylang Bahru, #01-02, Singapore 339708  
Telephone Number : +65 6294 2566  
Email Address : [info@chuankok.com](mailto:info@chuankok.com)  
Website : [www.chuankok.com](http://www.chuankok.com)  
Business Registration Number : 198201577Z  
Country of Registration : Singapore

### Conditions of Use of Catalogue:

The information in the catalogue are not binding and in order to improve distribution, Chuan Kok Hardware & Machinery Pte Ltd reserves the right to make any change including size and pressure ratings considered necessary at any time and without prior notice. According to the copyright and the civil law, any reproduction (also partial) of figures and texts of this catalogue by means of electronic, mechanical, photocopies, microfilms, recordings or other is forbidden without Chuan Kok Hardware & Machinery Pte Ltd's authorization.  
Catalogue Version: 2021

