

HYDRAULIC SAE FLANGES

Full Catalogue

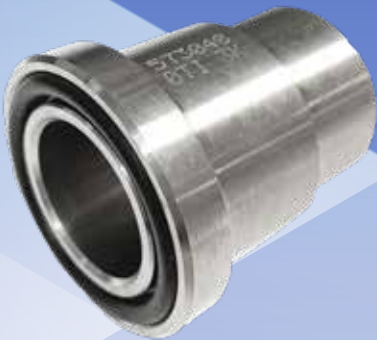

Hydraulic SAE Flanges

Specifications:

SAE-J518/ISO 6162, Hydraulic flanged tube, pipe and hose connections, four-bolt split flange type

Material Specifications:

ST52.3
 SS316

Size Range:

Code 61 (Series 3000): 3/8"NB – 5"NB
 Code 62 (Series 6000): 3/8"NB – 3"NB



Working Pressure:

Code 61 (Series 3000): 34 – 345 Bar
 Code 62 (Series 6000): 200 – 414 Bar

Temperature:

Carbon steel: -40°C - +120°C
 Stainless steel: -60°C - +50°C

Working pressure for material stainless steel shall be reduced if exceed certain temperature:

40% above +50°C to < +100°C
 11% above +100°C to < +200°C
 20% above +200°C to < +250°C

Orings:

NBR (Standard), Viton (Optional)

Flange Screws:

Metric screws according to DIN 912-8.8 (Standard)
 Metric screws according to DIN 912-10.9 (Optional)

SAE Flange Recommended Torque Values

Code 61 (Series 3000)

Flange Size	Recommended Torque Range N/m
1/2"	32
3/4"	70
1"	70
1 1/4"	70
1 1/2"	130
2"	130
2 1/2"	130
3"	295
3 1/2"	295
4"	295
5"	295

Code 62 (Series 6000)

Flange Size	Recommended Torque Range N/m (+10% -0)
1/2"	32
3/4"	70
1"	130
1 1/4"	130
1 1/2"	295
2"	550
2 1/2"	550
3"	650

Index

Type	Page No.
Weld In Double Flanges	3
Weld On Double Flanges SCHXXS	4
Weld On Double Flanges SCH160	5
Weld On Double Flanges SCH80	6
BSP Threaded Double Flanges	7
NPT Threaded Double Flanges	9

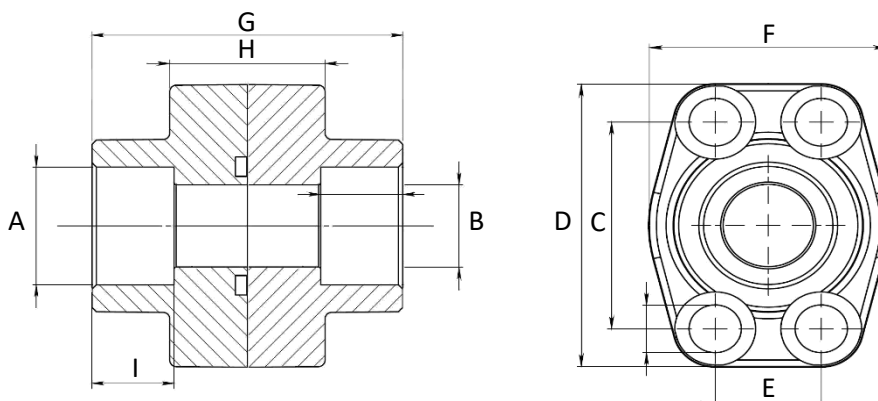
WELD IN DOUBLE FLANGES

Series 3000

WP (Bar)	Size	Type	Dimensions									
			A	B	C	D	E	F	G	H	I	Screws
345	1/2"	DFS080S	21.6	13	38.10	54	17.48	46	72	32	19	M8 x 30
345	1/2"	DFS080S038	17.5	13	38.10	54	17.48	46	72	32	19	M8 x 30
345	3/4"	DFS100S	27.2	19	47.63	65	22.23	50	72	36	19	M10 x 35
345	1"	DFS102S	34.0	25	52.37	70	26.19	55	76	36	19	M10 x 35
276	1 1/4"	DFS104S	42.8	32	58.72	79	30.18	68	82	42	22	M10 x 40
207	1 1/2"	DFS106S	48.6	38	69.85	93	35.71	78	90	50	24	M12 x 45
207	2"	DFS108S	61.0	51	77.77	102	42.88	90	90	50	26	M12 x 45
172	2 1/2"	DFS110S	76.6	63	88.90	114	50.80	105	100	50	30	M12 x 45
138	3"	DFS112S	90.5	73	106.38	134	61.93	124	100	54	34	M16 x 50
34	3 1/2"	DFS114S	103.0	89	120.65	152	69.85	136	96	54	34	M16 x 50
34	4"	DFS116S	115.5	97	130.18	162	77.77	146	96	54	34	M16 x 50
34	5"	DFS118S	141.3	120	152.40	184	92.08	180	100	56	28	M16 x 50

Series 6000

WP (Bar)	Size	Type	Dimensions									
			A	B	C	D	E	F	G	H	I	Screws
414	1/2"	DFS401S012	21.6	13	40.49	57	18.24	46	72	32	19	M8 x 30
414	1/2"	DFS401S038	17.5	13	40.49	57	18.24	46	72	32	19	M8 x 30
414	3/4"	DFS402S	27.2	19	50.80	71	23.80	55	70	42	22	M10 x 40
414	1"	DFS403S	34.0	25	57.15	81	27.76	65	82	42	22	M12 x 45
414	1 1/4"	DFS404S	42.8	32	66.68	95	31.75	78	88	50	25	M14 x 45
414	1 1/2"	DFS405S	48.6	38	79.38	112	36.50	94	100	60	28	M16 x 50
414	2"	DFS406S	61.0	51	96.82	134	44.45	114	130	74	24	M20 x 70
414	2 1/2"	DFS507S	76.6	63	123.80	180	58.70	152	160	90	30	M24 x 80
414	3"	DFS508S	90.5	73	152.40	208	71.40	178	180	110	30	M30 x 100

Designation for Order:

Double Flanges

(Flat side & Oring side)

ST52.3	DFS...S
SS316	DFX...S

Counter-Flanges

(Flat side)

ST52.3	GFS...S
SS316	GFX...S

Flanges

(Oring side)

ST52.3	AFS...S
SS316	AFX...S

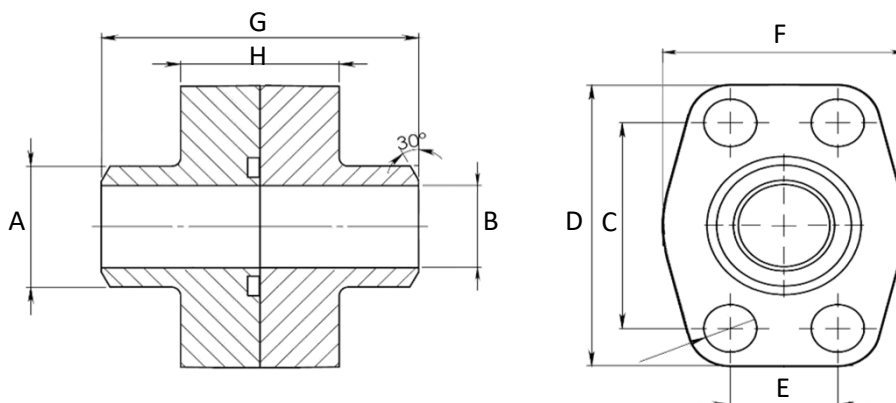
WELD ON DOUBLE FLANGES SCHXXS

Series 3000

WP (Bar)	Size	Type	Dimensions								
			A	B	C	D	E	F	G	H	Screws
345	1/2"	DFS080STB6	21.5	6.3	38.10	54	17.48	46	72	32	M8 x 30
345	3/4"	DFS100STB11	28.0	11.0	47.63	65	22.23	50	72	36	M10 x 35
345	1"	DFS102STB15	34.0	15.2	52.37	70	26.19	55	76	36	M10 x 35
276	1 1/4"	DFS104STB22	42.8	22.8	58.72	79	30.18	68	82	42	M10 x 40
207	1 1/2"	DFS106STB28	48.6	28.0	69.85	93	35.71	78	90	50	M12 x 45
207	2"	DFS108STB38	61.0	38.2	77.77	102	42.88	90	90	50	M12 x 45
172	2 1/2"	DFS110STB45	77.0	45.0	88.90	114	50.80	105	100	50	M12 x 45
138	3"	DFS112STB58	92.0	58.4	106.38	134	61.93	124	100	54	M16 x 50
34	4"	DFS116STB80	115.5	80.0	130.18	162	77.77	146	96	54	M16 x 50
34	5"	DFS118STB102	141.3	102.9	152.40	184	92.08	180	100	56	M16 x 50

Series 6000

WP (Bar)	Size	Type	Dimensions								
			A	B	C	D	E	F	G	H	Screws
414	1/2"	DFS401STB012B6	21.5	6.3	40.49	54	18.24	46	72	32	M8 x 30
414	3/4"	DFS402STB11	28.0	11.0	50.80	71	23.80	55	70	42	M10 x 40
414	1"	DFS403STB15	34.0	15.2	57.15	81	27.76	65	82	42	M12 x 45
414	1 1/4"	DFS404STB22	42.8	22.8	66.68	95	31.75	78	88	50	M14 x 45
414	1 1/2"	DFS405STB28	48.6	28.0	79.38	112	36.50	94	100	60	M16 x 50
414	2"	DFS406STB38	61.0	38.2	96.82	134	44.45	114	130	74	M20 x 70
414	2 1/2"	DFS507STB45	76.6	45.0	123.80	180	58.70	152	160	90	M24 x 80
414	3"	DFS508STB58	90.0	58.4	152.40	208	71.40	178	180	110	M30 x 100

Designation for Order:

Double Flanges

(Flat side & Oring side)

ST52.3	DFS...STB
SS316	DFX...STB

Counter-Flanges

(Flat side)

ST52.3	GFS...STB
SS316	GFX...STB

Flanges

(Oring side)

ST52.3	AFS...STB
SS316	AFX...STB

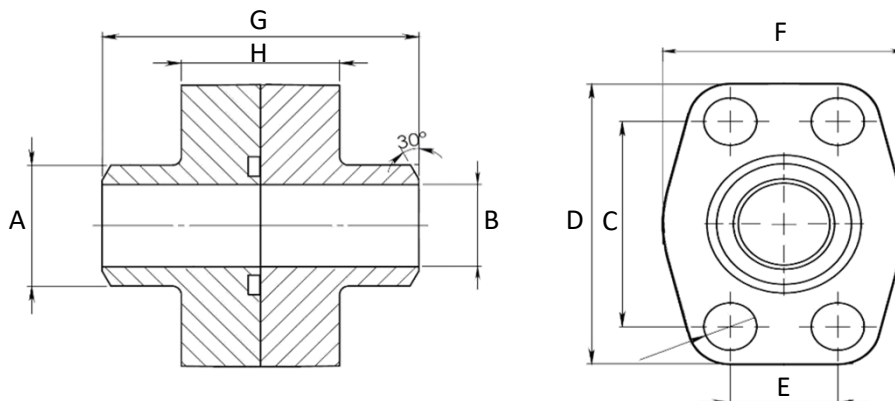
WELD ON DOUBLE FLANGES SCH160

Series 3000

WP (Bar)	Size	Type	Dimensions								
			A	B	C	D	E	F	G	H	Screws
345	1/2"	DFS080STB11	21.5	11.8	38.10	54	17.48	46	72	32	M8 x 30
345	3/4"	DFS100STB15	28.0	15.6	47.63	65	22.23	50	72	36	M10 x 35
345	1"	DFS102STB20	34.0	20.7	52.37	70	26.19	55	76	36	M10 x 35
276	1 1/4"	DFS104STB29	42.8	29.5	58.72	79	30.18	68	82	42	M10 x 40
207	1 1/2"	DFS106STB34	48.6	34.0	69.85	93	35.71	78	90	50	M12 x 45
207	2"	DFS108STB42	61.0	42.8	77.77	102	42.88	90	90	50	M12 x 45
172	2 1/2"	DFS110STB54	77.0	54.0	88.90	114	50.80	105	100	50	M12 x 45
138	3"	DFS112STB67	92.0	67.7	106.38	134	61.93	124	100	54	M16 x 50
34	4"	DFS116STB87	115.5	87.3	130.18	162	77.77	146	96	54	M16 x 50
34	5"	DFS118STB109	141.3	109.5	152.40	184	92.08	180	100	56	M16 x 50

Series 6000

WP (Bar)	Size	Type	Dimensions								
			A	B	C	D	E	F	G	H	Screws
414	1/2"	DFS401ST012B11	21.5	11.8	40.49	54	18.24	46	72	32	M8 x 30
414	3/4"	DFS402STB15	28.0	15.6	50.80	71	23.80	55	70	42	M10 x 40
414	1"	DFS403STB20	34.0	20.7	57.15	81	27.76	65	82	42	M12 x 45
414	1 1/4"	DFS404STB29	42.8	29.5	66.68	95	31.75	78	88	50	M14 x 45
414	1 1/2"	DFS405STB34	48.6	34.0	79.38	112	36.50	94	100	60	M16 x 50
414	2"	DFS406STB42	61.0	42.8	96.82	134	44.45	114	130	74	M20 x 70
350	2 1/2"	DFS507STB54	76.6	54.0	123.80	180	58.70	152	160	90	M24 x 80
350	3"	DFS508STB67	90.0	67.7	152.40	208	71.40	178	180	110	M30 x 100

Designation for Order:

Double Flanges
 (Flat side & Oring side)

ST52.3	DFS...STB
SS316	DFX...STB

Counter-Flanges
 (Flat side)

ST52.3	GFS...STB
SS316	GFX...STB

Flanges
 (Oring side)

ST52.3	AFS...STB
SS316	AFX...STB

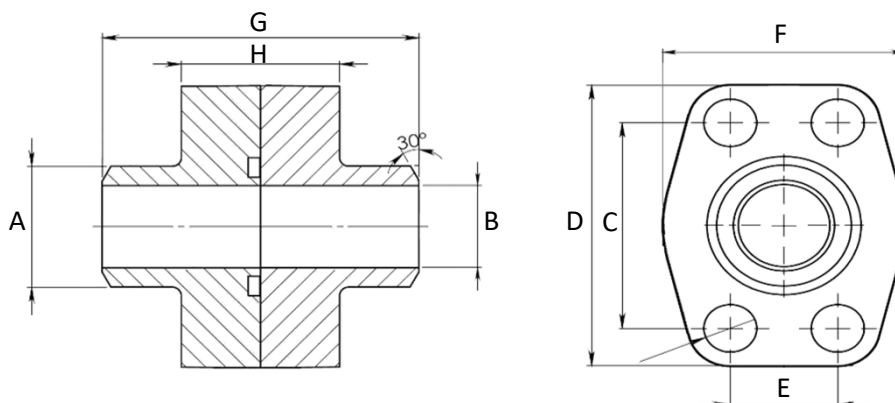
WELD ON DOUBLE FLANGES SCH80

Series 3000

WP (Bar)	Size	Type	Dimensions								
			A	B	C	D	E	F	G	H	Screws
345	1/2"	DFS080ST	21.5	13.0	38.10	54	17.48	46	72	32	M8 x 30
345	1/2"	DFS080ST038	17.5	13.0	38.10	54	17.48	46	72	32	M8 x 30
345	3/4"	DFS100ST	28.0	19.0	47.63	65	22.23	50	72	36	M10 x 35
345	1"	DFS102ST	34.0	25.0	52.37	70	26.19	55	76	36	M10 x 35
276	1 1/4"	DFS104ST	42.8	32.0	58.72	79	30.18	68	82	42	M10 x 40
207	1 1/2"	DFS106ST	48.6	38.0	69.85	93	35.71	78	90	50	M12 x 45
207	2"	DFS108ST	61.0	49.0	77.77	102	42.88	90	90	50	M12 x 45
172	2 1/2"	DFS110ST	77.0	59.0	88.90	114	50.80	105	100	50	M12 x 45
138	3"	DFS112ST	92.0	73.0	106.38	134	61.93	124	100	54	M16 x 50
34	3 1/2"	DFS114ST	103.0	85.0	120.65	152	69.85	136	96	54	M16 x 50

Series 6000

WP (Bar)	Size	Type	Dimensions								
			A	B	C	D	E	F	G	H	Screws
414	1/2"	DFS401ST012	21.5	13.0	40.49	54	18.24	46	72	32	M8 x 30
414	1/2"	DFS401ST038	17.5	13.0	40.49	54	18.24	46	72	32	M8 x 30
414	3/4"	DFS402ST	28.0	19.0	50.80	71	23.80	55	70	42	M10 x 40
414	1"	DFS403ST	34.0	25.0	57.15	81	27.76	65	82	42	M12 x 45
375	1 1/4"	DFS404ST	42.8	32.0	66.68	95	31.75	78	88	50	M14 x 45
320	1 1/2"	DFS405ST	48.6	38.0	79.38	112	36.50	94	100	60	M16 x 50
250	2"	DFS406ST	61.0	49.0	96.82	134	44.45	114	130	74	M20 x 70
230	2 1/2"	DFS507ST	76.6	59.0	123.80	180	58.70	152	160	90	M24 x 80
200	3"	DFS508ST	90.0	73.0	152.40	208	71.40	178	180	110	M30 x 100

Designation for Order:

 Double Flanges
 (Flat side & Oring side)

ST52.3	DFS...ST
SS316	DFX...ST

 Counter-Flanges
 (Flat side)

ST52.3	GFS...ST
SS316	GFX...ST

 Flanges
 (Oring side)

ST52.3	AFS...ST
SS316	AFX...ST

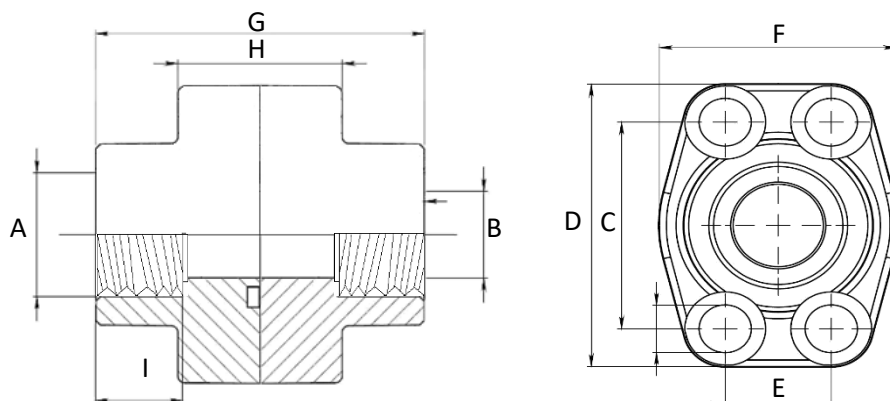
BSP THREADED DOUBLE FLANGES

Series 3000

WP (Bar)	Size	Type	Dimensions									
			A	B	C	D	E	F	G	H	I	Screws
345	1/2"	DFS080G	1/2"	13	38.10	57	17.48	46	72	32	19	M8x30
345	1/2"	DFS080G038	3/8"	13	38.10	57	17.48	46	72	32	19	M8x30
345	3/4"	DFS100G	3/4"	19	47.63	65	22.23	50	72	36	19	M10x35
345	3/4"	DFS100G012	1/2"	13	47.63	65	22.23	50	72	36	19	M10x35
345	1"	DFS102G	1"	25	52.37	70	26.19	55	76	36	22	M10x35
345	1"	DFS102G034	3/4"	19	52.37	70	26.19	55	70	42	19	M10x40
276	1 1/4"	DFS104G	1 1/4"	32	58.72	79	30.18	68	82	42	22	M10x40
276	1 1/4"	DFS104G100	1"	25	58.72	81	30.18	52	84	50	22	M10x40
207	1 1/2"	DFS106G	1 1/2"	38	69.85	93	35.71	78	90	50	24	M12x45
207	1 1/2"	DFS106G114	1 1/4"	32	69.85	95	35.71	78	90	54	22	M12x45
207	2"	DFS108G	2"	51	77.77	102	42.88	90	90	50	30	M12x45
207	2"	DFS108G112	1 1/2"	38	77.77	102	42.88	90	90	50	24	M12x45
172	2 1/2"	DFS110G	2 1/2"	63	88.90	114	50.80	105	100	50	30	M12x45
173	2 1/2"	DFS110G200	2"	51	88.90	114	50.80	105	100	50	30	M12x45
138	3"	DFS112G	3"	73	106.38	134	61.93	124	100	54	34	M16x50
138	3"	DFS112G212	2 1/2"	63	106.38	134	61.93	124	100	54	30	M16x50
34	3 1/2"	DFS114G	3 1/2"	89	120.65	152	69.85	136	96	54	34	M16x50
34	3 1/2"	DFS114G300	3"	73	120.65	152	69.85	136	96	54	34	M16x50
34	4"	DFS116G	4"	99	130.18	162	77.77	146	96	54	34	M16x50
34	4"	DFS116G312	3 1/2"	89	130.18	162	77.77	146	96	54	34	M16x50
34	5"	DFS118G	5"	120	152.40	184	92.08	180	100	60	30	M16x55

Designation for Order:

Double Flanges

(Flat side & Oring side)

ST52.3	DFS...S
SS316	DFX...S

Counter-Flanges

(Flat side)

ST52.3	GFS...S
SS316	GFX...S

Flanges

(Oring side)

ST52.3	AFS...S
SS316	AFX...S

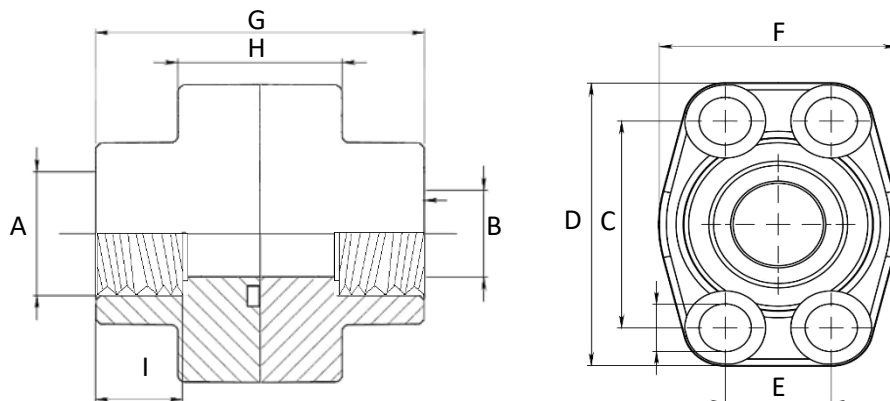
BSP THREADED DOUBLE FLANGES

Series 6000

WP (Bar)	Size	Type	Dimensions									
			A	B	C	D	E	F	G	H	I	Screws
414	1/2"	DFS401G012	1/2"	13	40,49	57	18,24	46	72	32	19	M8x30
414	1/2"	DFS401G038	3/8"	13	40,49	57	18,24	46	72	32	19	M8x30
414	3/4"	DFS402G	3/4"	19	50,80	71	23,80	55	70	42	22	M10x40
414	3/4"	DFS402G012	1/2"	13	50,80	71	23,80	55	70	42	19	M10x40
414	1"	DFS403G	1"	25	57,15	81	27,76	65	84	50	24	M12x45
414	1"	DFS403G034	3/4"	19	57,15	81	27,76	65	84	50	22	M12x45
414	1 1/4"	DFS404G	1 1/4"	32	66,68	95	31,75	78	90	54	25	M14x45
414	1 1/4"	DFS404GL13	1 1/4"	32	66,68	95	31,75	78	90	54	25	M12x45
414	1 1/4"	DFS404G100	1"	25	66,68	95	31,75	78	90	54	24	M14x45
414	1 1/4"	DFS404G100L13	1"	25	66,68	95	31,75	78	90	54	24	M12x45
414	1 1/2"	DFS405G	1 1/2"	38	79,38	112	36,50	94	100	60	28	M16x55
414	1 1/2"	DFS405G114	1 1/4"	32	79,38	112	36,50	94	100	60	25	M16x55
414	2"	DFS406G	2"	51	96,82	134	44,45	114	130	74	30	M20x70
414	2"	DFS406G112	1 1/2"	38	96,82	134	44,45	114	130	74	28	M20x70
414	2 1/2"	DFS507G	2 1/2"	63	123,80	180	58,70	152	160	90	35	M24x80
414	3"	DFS508G	3"	73	152,40	208	71,40	178	180	110	40	M30x100

Designation for Order:

Double Flanges

(Flat side & Oring side)

ST52.3	DFS...S
SS316	DFX...S

Counter-Flanges

(Flat side)

ST52.3	GFS...S
SS316	GFX...S

Flanges

(Oring side)

ST52.3	AFS...S
SS316	AFX...S

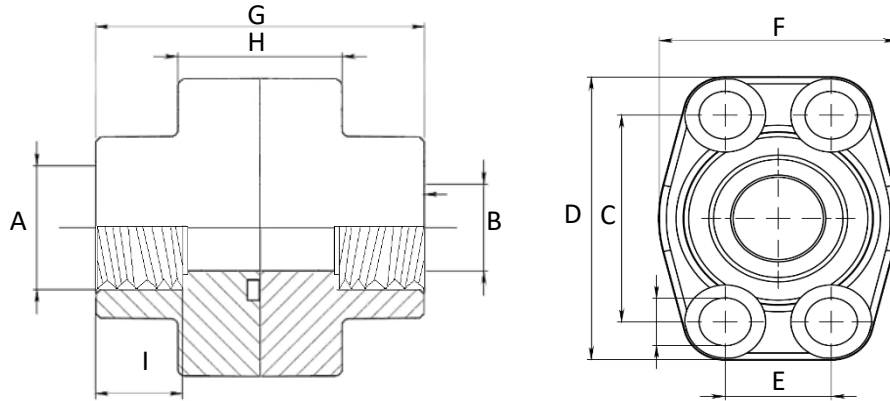
NPT THREADED DOUBLE FLANGES

Series 3000

WP (Bar)	Size	Type	Dimensions									
			A	B	C	D	E	F	G	H	I	Screws
345	1/2"	DFS080N	1/2"	13	38,10	57	17,48	46	72	32	19	M8x30
345	1/2"	DFS080N038	3/8"	13	38,10	57	17,48	46	72	32	19	M8x30
345	3/4"	DFS100N	3/4"	19	47,63	65	22,23	50	72	36	19	M10x35
345	3/4"	DFS100N012	1/2"	13	47,63	65	22,23	50	72	36	19	M10x35
345	1"	DFS102N	1"	25	52,37	70	26,19	55	76	36	22	M10x35
345	1"	DFS102N034	3/4"	19	52,37	70	26,19	55	70	42	19	M10x40
276	1 1/4"	DFS104N	1 1/4"	32	58,72	79	30,18	68	82	42	22	M10x40
276	1 1/4"	DFS104N100	1"	25	58,72	81	30,18	65	84	50	22	M10x40
207	1 1/2"	DFS106N	1 1/2"	38	69,85	93	35,71	78	90	50	24	M12x45
207	1 1/2"	DFS106N114	1 1/4"	32	69,85	95	35,71	78	90	54	22	M12x45
207	2"	DFS108N	2"	51	77,77	102	42,88	90	90	50	30	M12x45
207	2"	DFS108N112	1 1/2"	38	77,77	102	42,88	90	90	50	24	M12x45
172	2 1/2"	DFS110N	2 1/2"	63	88,90	114	50,80	105	100	50	30	M12x45
138	3"	DFS112N	3"	73	106,38	134	61,93	124	100	54	34	M16x50
34	3 1/2"	DFS114N	3 1/2"	89	120,65	152	69,85	136	96	54	34	M16x50
34	4"	DFS116N	4"	99	130,18	162	77,77	146	96	54	34	M16x50
34	5"	DFS118N	5"	120	152,40	184	92,08	180	100	56	30	M16x55

Designation for Order:

 Double Flanges
 (Flat side & Oring side)

ST52.3	DFS...STB
SS316	DFX...STB

 Counter-Flanges
 (Flat side)

ST52.3	GFS...STB
SS316	GFX...STB

 Flanges
 (Oring side)

ST52.3	AFS...STB
SS316	AFX...STB

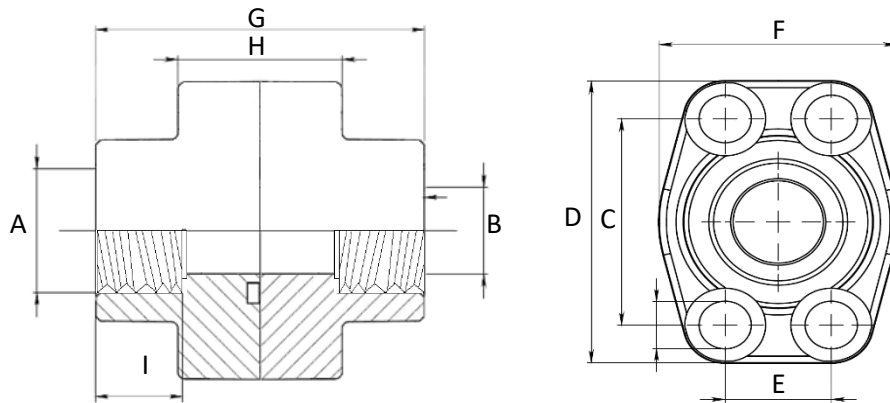
NPT THREADED DOUBLE FLANGES

Series 6000

WP (Bar)	Size	Type	Dimensions									
			A	B	C	D	E	F	G	H	I	Screws
414	1/2"	DFS401N012	1/2"	13	40,49	57	18,24	46	72	32	19	M8x30
414	1/2"	DFS401N038	3/8"	13	40,49	57	18,24	46	72	32	19	M8x30
414	3/4"	DFS402N	3/4"	19	50,80	71	23,80	55	70	42	22	M10x40
414	3/4"	DFS402N012	1/2"	13	50,80	71	23,80	55	70	42	19	M10x40
414	1"	DFS403N	1"	25	57,15	81	27,76	65	84	50	24	M12x45
414	1"	DFS403N034	3/4"	19	57,15	81	27,76	65	84	50	22	M12x45
414	1 1/4"	DFS404N	1 1/4"	32	66,68	95	31,75	78	90	54	25	M14x45
414	1 1/4"	DFS404NL13	1 1/4"	32	66,68	95	31,75	78	90	54	25	M12x45
414	1 1/4"	DFS404N100	1"	25	66,68	95	31,75	78	90	54	24	M14x45
414	1 1/4"	DFS404N100L13	1"	25	66,68	95	31,75	78	90	54	24	M12x45
414	1 1/2"	DFS405N	1 1/2"	38	79,38	112	36,50	94	100	60	28	M16x55
414	1 1/2"	DFS405N114	1 1/4"	32	79,38	112	36,50	94	100	60	25	M16x55
414	2"	DFS406N	2"	51	96,82	134	44,45	114	130	74	30	M20x70
414	2"	DFS406N112	1 1/2"	38	96,82	134	44,45	114	130	74	28	M20x70
414	2 1/2"	DFS507N	2 1/2"	63	123,80	180	58,70	152	160	90	35	M24x80
414	3"	DFS508N	3"	73	152,40	208	71,40	178	180	110	40	M30x100

Designation for Order:

 Double Flanges
 (Flat side & Oring side)

ST52.3	DFS...STB
SS316	DFX...STB

 Counter-Flanges
 (Flat side)

ST52.3	GFS...STB
SS316	GFX...STB

 Flanges
 (Oring side)

ST52.3	AFS...STB
SS316	AFX...STB

Chuan Kok Hardware & Machinery Pte Ltd

Address : 1783 Geylang Bahru, #01-02, Singapore 339708
Telephone Number : +65 6294 2566
Email Address : info@chuankok.com
Website : www.chuankok.com
Business Registration Number : 198201577Z
Country of Registration : Singapore

Conditions of Use of Catalogue:

The information in the catalogue are not binding and in order to improve distribution, Chuan Kok Hardware & Machinery Pte Ltd reserves the right to make any change including size and pressure ratings considered necessary at any time and without prior notice. According to the copyright and the civil law, any reproduction (also partial) of figures and texts of this catalogue by means of electronic, mechanical, photocopies, microfilms, recordings or other is forbidden without Chuan Kok Hardware & Machinery Pte Ltd's authorization.
Catalogue Version: 2021

