

JIS 10K

Stainless Steel

GLOBE VALVES



Features

- JIS 10K Flange Connection
- Size: 1" – 1 1/2" (DN25 – DN40)
- Valve Body Material: SS316
- Working Pressure: 10kg/cm²
- Applicable Medium: General oil, gas and water applications
- Temperature Range: -29°C to 425°C



**JIS 10K SS316
Flange End Globe Valves**

Material List

No.	Part Name	Material
1	Body + Seat	ASTM A182 F316
2	Disc	ASTM A182 F316
3	Stem	ASTM A182 F316
4	Gasket	SS316 + Graphite
5	Bonnet	ASTM A182 F316
6	Bonnet Bolt	ASTM A193 B8M
7	Packing	Graphite
8	Pin	ASTM A182 F316
9	Gland	ASTM A182 F316
10	Gland Flange	ASTM A182 F316
11	Gland Bolt	ASTM A193 B8M
12	Gland Nut	ASTM A194 8M
13	Yoke Sleeve	ASTM A276 410
14	Lock Nut	Carbon Steel
15	Handwheel	ASTM A197

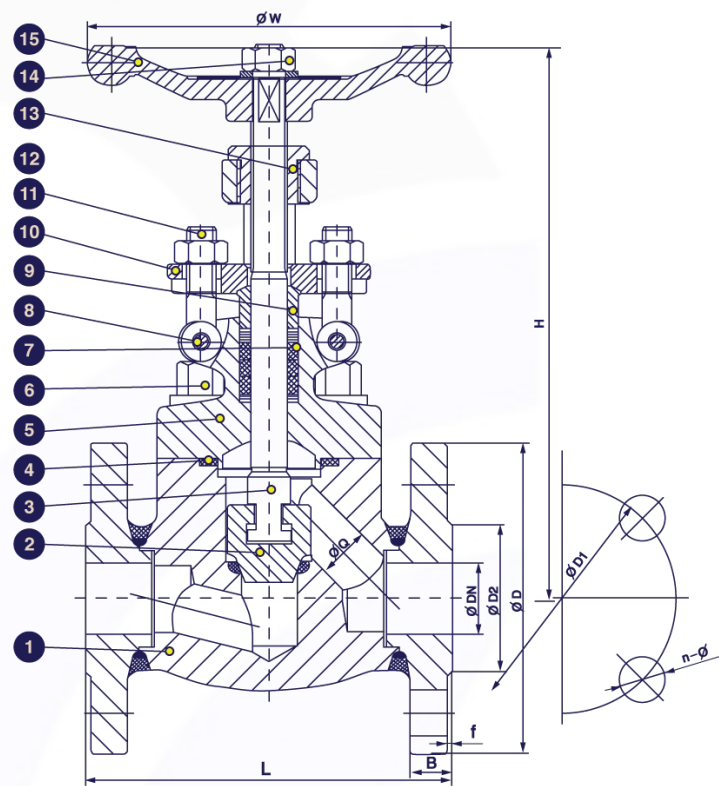

Technical Specifications

1. Basic design and manufacture according to API602/BS5352
2. Face to face dimension: ASME B16.10
3. Flange End: JIS B2220;2012 RF
4. Inspection and test: API 598

Main Technical Parameter			
Normal pressure		10K	MPa
Test pressure	Shell test pressure	3.0	
	Seal test	2.2	
	Gas test	0.6	
Max working temperature		-29°C to 425°C	
Applicable Medium: General oil, gas & water			

Features

- JIS 10K Flange Connection
- Size: 2" – 4" (DN50 – DN100)
- Valve Body Material: SS316
- Working Pressure: 10kg/cm²
- Applicable Medium: General oil, gas and water applications
- Temperature Range: ≤ 425°C



**JIS 10K SS316
Flange End Globe Valves**

Material List

No.	Part Name	Material
1	Body	A351 CF8M
2	Disc	SS316
3	Grand	SS316
4	Stem	SS316
5	Bolt	A193 B8M
6	Nut	A194 B8M
7	Gasket	SS316 + Graphite
8	Packing	Graphite
9	Pin	SS304
10	Gland Nut	SS316
11	Packing Gland	A351 CF8M
12	Eye bolt	A193 B8M
13	Bonnet	A351 CF8M
14	Stem Nut	A439 D2
15	Screw	AISI 1025
16	Handwheel	A216 WCB
17	Gasket	SS316
18	Nut	A194 B8M

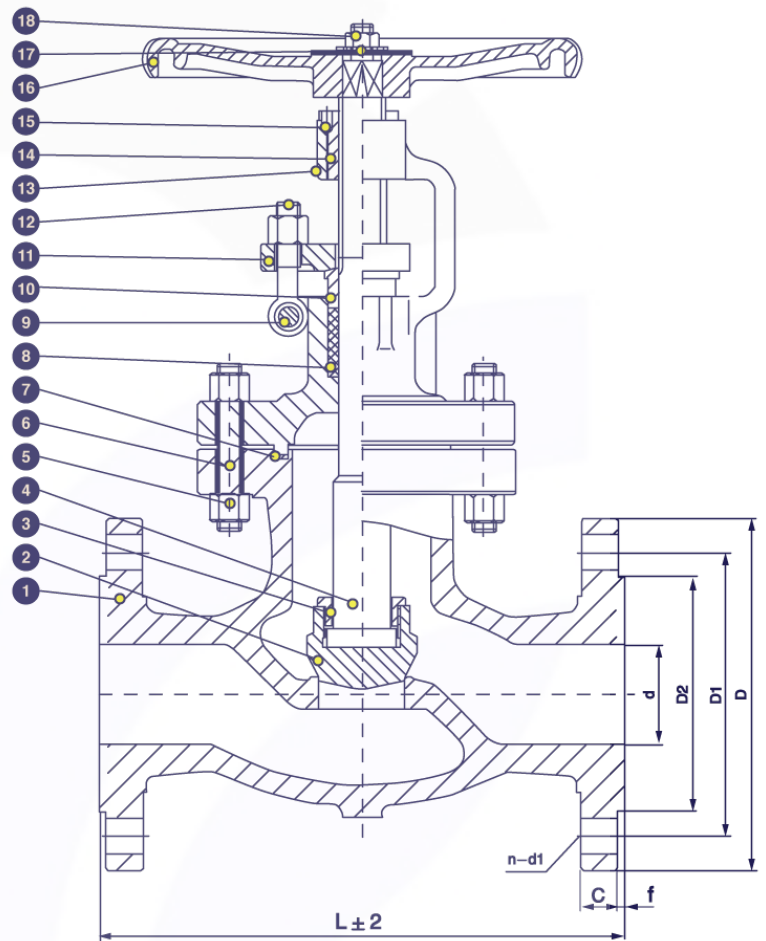

Technical Specifications

5. Basic design and manufacture according to ASME B16.34 & BS 1873
6. Face to face dimension: ASME B16.10
7. Flange End: JIS 2238
8. Inspection and test: JIS F7400

Main Technical Parameter			
Normal pressure		10K	MPa
Test pressure	Shell test pressure	3.0	
	Seal test	2.2	
	Back seal test	2.2	
	Gas test	0.6	
Max working temperature		≤ 425°C	
Applicable Medium: General oil, gas & water			

Ordering Information

VL	-	S	-	GL	-	F	-	10K	-	16
I		II		III		IV		V		VI

I	Type of Item		
VL	Low Pressure Valves		

II	Material Grade		
S	SS316, CF8M	CI	Cast Iron
FS	Forged Steel	CS	Cast Steel
B	Brass		

III	Item		
GA	Gate Valve	B1	1 PC Ball Valve
GL	Globe Valve	B2	2 PC Ball Valve
YS	Y-Strainer	B3	3 PC Ball Valve
SC	Swing Check Valve	BL	3 Way Ball Valve L Port
VC	Vertical Check Valve	BT	3 Way Ball Valve T Port
WC	Wafer Check Valve	BMF	Male x Female Mini Ball Valve
DD	Dual Disk	BU	Butterfly Valve

IV	Connection Type		
SW	S/W	G	BSPP
BW	B/W	N	NPT
R	BSPT	F	Flange End
W	Wafer	L	Lug

V	Pressure		
200	200 PSI	2000	2000 PSI
300	300 PSI	150	ANSI 150# Flange Standard
600	600 PSI	10K	JIS 10K Flange Standard
800	800 PSI	PN16	PN 16 Flange Standard
1000	1000 PSI		

For Inch OD & Inch NB Sizes

VI	Size							
Size	1/8"	1/4"	5/16"	3/8"	1/2"	5/8"	3/4"	1"
Code	02	04	05	06	08	10	12	16
Size	1 1/4"	1 1/2"	2"	2 1/2"	3"	4"	5"	6"
Code	20	24	32	40	48	64	80	96

VII	Coating		
(None)	No Additional Coating		
NI	Nickel Plating		

Dimension List

DN25 – DN40

NPS	Part No	Q	D	D1	D2	L	W	H	B	f	n-Øz	Weight (Kg)
1"	VL-S-GL-F-10K-16	18	125	90	67	127	125	203	14	1	4-Ø16	6.01
1 1/4"	VL-S-GL-F-10K-20	23	135	100	76	140	160	224	16	2	4-Ø16	8.84
1 1/2"	VL-S-GL-F-10K-24	28	140	105	81	165	160	260	16	2	4-Ø16	10.25

DN50 – DN100

NPS	Part No	d	D	D1	D2	C	f	L	n-d1	Weight (Kg)
2"	VL-S-GL-F-10K-32	50.0	156	120	100	15.5	2	201	4-Ø19	13.00
2-1/2"	VL-S-GL-F-10K-40	63.5	175	140	120	17.5	2	215	4-Ø19	17.75
3"	VL-S-GL-F-10K-48	77.0	186	150	130	18.5	2	240	8-Ø19	20.75
4"	VL-S-GL-F-10K-64	100.5	211	175	155	18.5	2	291	8-Ø19	33.15

Part Number Reference

Part No	Description
VL-S-GL-F-10K-16	1"JIS10K SS316 FLANGE END GLOBE VALVE RISING STEM, HANDWHEEL OPERATED
VL-S-GL-F-10K-20	1 1/4"JIS10K SS316 FLANGE END GLOBE VALVE RISING STEM, HANDWHEEL OPERATED
VL-S-GL-F-10K-24	1 1/2"JIS10K SS316 FLANGE END GLOBE VALVE RISING STEM, HANDWHEEL OPERATED
VL-S-GL-F-10K-32	2"JIS10K SS316 FLANGE END GLOBE VALVE RISING STEM, HANDWHEEL OPERATED
VL-S-GL-F-10K-40	2 1/2"JIS10K SS316 FLANGE END GLOBE VALVE RISING STEM, HANDWHEEL OPERATED
VL-S-GL-F-10K-48	3"JIS10K SS316 FLANGE END GLOBE VALVE RISING STEM, HANDWHEEL OPERATED
VL-S-GL-F-10K-64	4"JIS10K SS316 FLANGE END GLOBE VALVE RISING STEM, HANDWHEEL OPERATED



AF HYDRO

Conditions of Use of Catalogue:

The information in the catalogue are not binding and in order to improve distribution, AF Hydro reserves the right to make any change including size and pressure ratings considered necessary at any time and without prior notice. According to the copyright and the civil law, any reproduction (also partial) of figures and texts of this catalogue by means of electronic, mechanical, photocopies, microfilms, recordings or other is forbidden without AF Hydro's authorization.