

JIS 10K

Stainless Steel SWING CHECK VALVES



Features

- Swing Type
- JIS 10K Flange Connection
- Size: 3" - 4" (DN80 - DN100)
- Working Pressure: 10kg/cm²
- Material: SS316, SCS14A
- Applicable Medium: General oil, gas & water applications
- Temperature Range: -29°C to 150°C



JIS 10K SS316 Flange End
Swing Check Valves

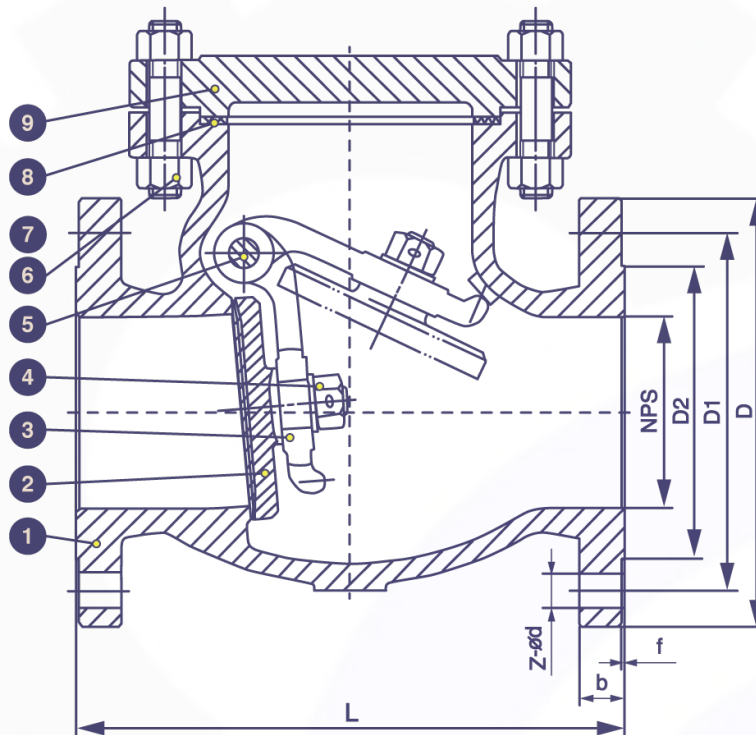

Technical Specifications

1. Basic design and manufacture according to JIS B2084
2. Structure length according to JIS B2002
3. Flange ends complied with JIS B2220
4. Inspection and tested according to JIS B2003

Performance Specification Sheet			
Nominal pressure		10K	
Test pressure	Shell test	3.0	MPa
	Seal test	2.2	
	Air seal test	0.4 - 0.7	
Applicable Medium: General oil, gas & water			

Ordering Information

VL	-	S	-	SC	-	F	-	10K	-	48
I		II		III		IV		V		VI

I	Type of Item		
VL	Low Pressure Valves		

II	Material Grade		
S	SS316, CF8M	CI	Cast Iron
FS	Forged Steel	CS	Cast Steel
B	Brass		

III	Item		
GA	Gate Valve	B1	1 PC Ball Valve
GL	Globe Valve	B2	2 PC Ball Valve
YS	Y-Strainer	B3	3 PC Ball Valve
SC	Swing Check Valve	BL	3 Way Ball Valve L Port
VC	Vertical Check Valve	BT	3 Way Ball Valve T Port
WC	Wafer Check Valve	BMF	Male x Female Mini Ball Valve
DD	Dual Disk	BU	Butterfly Valve

IV	Connection Type		
SW	S/W	G	BSPP
BW	B/W	N	NPT
R	BSPT	F	Flange End
W	Wafer	L	Lug

V	Pressure		
200	200 PSI	2000	2000 PSI
300	300 PSI	150	ANSI 150# Flange Standard
600	600 PSI	10K	JIS 10K Flange Standard
800	800 PSI	PN16	PN 16 Flange Standard
1000	1000 PSI		

For Inch OD & Inch NB Sizes

VI	Size							
Size	1/8"	1/4"	5/16"	3/8"	1/2"	5/8"	3/4"	1"
Code	02	04	05	06	08	10	12	16
Size	1 1/4"	1 1/2"	2"	2 1/2"	3"	4"	5"	6"
Code	20	24	32	40	48	64	80	96

VII	Coating		
(None)	No Additional Coating		
NI	Nickel Plating		

Material List

No.	Part Name	Material
1	Body	SCS14A/SS316
2	Disc	SCS14A/SS316
3	Arm	SCS14A/SS316
4	Nut	SS316
5	Hinge Pin	SS316
6	Bolt	SS316
7	Nut	SS316
8	Gasket	PTFE
9	Bonnet	SCS14A/SS316

Dimension List

Size	Connection	Impa Code	Part No	NPS	D	D1	D2	L	Z-Ød	b	f	Weight (Kg)
3"	Flange-end	-	VL-S-SC-F-10K-48	80	185	150	126	241	4-Ø19	18	2	21.00
4"	Flange-end	-	VL-S-SC-F-10K-64	100	210	175	151	292	8-Ø19	18	2	36.00

Part Number Reference

Impa Code	Part No	Description
-	VL-S-SC-F-10K-48	3" JIS 10K SS316 FLANGE END SWING CHECK VALVE
-	VL-S-SC-F-10K-64	4" JIS 10K SS316 FLANGE END SWING CHECK VALVE



AF HYDRO

Conditions of Use of Catalogue:

The information in the catalogue are not binding and in order to improve distribution, AF Hydro reserves the right to make any change including size and pressure ratings considered necessary at any time and without prior notice. According to the copyright and the civil law, any reproduction (also partial) of figures and texts of this catalogue by means of electronic, mechanical, photocopies, microfilms, recordings or other is forbidden without AF Hydro's authorization.