

ANSI 150#

# **Stainless Steel**

# **GATE VALVES**



### Features

- ANSI 150# Flange Connection
- Size: 1" – 4" (DN25 – DN100)
- Valve Body Material: SS316
- Working Pressure: 150#
- Applicable Medium: General oil, gas and water applications
- Temperature Range:  $\leq 425^{\circ}\text{C}$



ANSI 150# SS316  
Flange End Gate Valves

### Material List

No.	Part Name	Material
1	Body	A351 CF8M
2	Wedge	A351 CF8M
3	Stem	SS316
4	Gasket	SS316 + Graphite
5	Bolt	A193 B8M
6	Nut	A193 B8M
7	Packing	Graphite
8	Pin	SS304
9	Eye Bolt	A193 B8M
10	Gland Nut	SS316
11	Gland Flange	A351 CF8M
12	Bonnet	A351 CF8M
13	Nipple	Assembly
14	Stem Nut	A439 D2
15	Nut	AISI 1035
16	Handwheel	WCB
17	Lock Nut	AISI 1035

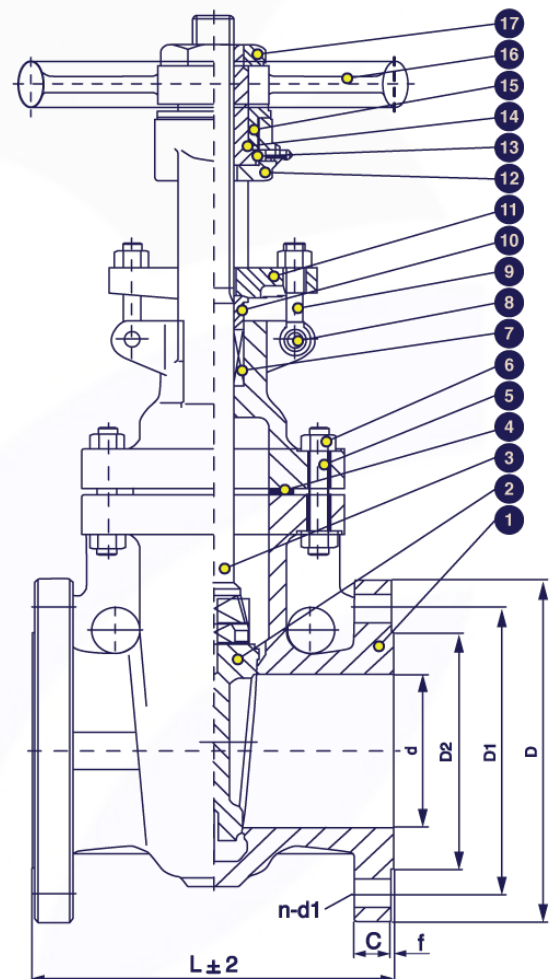

### Technical Specifications

1. Basic design and manufacture according to API 600
2. Face to face dimension: ASME B16.10
3. Flange End: ASME B16.5 RF
4. Inspection and test: API 598

Main Technical Parameter		
Normal pressure		150 PSI
Test pressure	Shell test pressure	3.0
	Seal test	2.2
	Back seal test	2.2
	Gas test	0.6
Max working temperature		$\leq 425^{\circ}\text{C}$
Applicable Medium: General oil, gas & water		

## Ordering Information

VL	-	S	-	GA	-	F	-	150	-	16
I		II		III		IV		V		VI

<b>I</b>	<b>Type of Item</b>		
VL	Low Pressure Valves		

<b>II</b>	<b>Material Grade</b>		
S	SS316, CF8M	CI	Cast Iron
FS	Forged Steel	CS	Cast Steel
B	Brass		

<b>III</b>	<b>Item</b>		
GA	Gate Valve	B1	1 PC Ball Valve
GL	Globe Valve	B2	2 PC Ball Valve
YS	Y-Strainer	B3	3 PC Ball Valve
SC	Swing Check Valve	BL	3 Way Ball Valve L Port
VC	Vertical Check Valve	BT	3 Way Ball Valve T Port
WC	Wafer Check Valve	BMF	Male x Female Mini Ball Valve
DD	Dual Disk	BU	Butterfly Valve

<b>IV</b>	<b>Connection Type</b>		
SW	S/W	G	BSPP
BW	B/W	N	NPT
R	BSPT	F	Flange End
W	Wafer	L	Lug

<b>V</b>	<b>Pressure</b>		
200	200 PSI	2000	2000 PSI
300	300 PSI	150	ANSI 150# Flange Standard
600	600 PSI	10K	JIS 10K Flange Standard
800	800 PSI	PN16	PN 16 Flange Standard
1000	1000 PSI		

## For Inch OD & Inch NB Sizes

<b>VI</b>	<b>Size</b>							
Size	1/8"	1/4"	5/16"	3/8"	1/2"	5/8"	3/4"	1"
Code	02	04	05	06	08	10	12	16
Size	1 1/4"	1 1/2"	2"	2 1/2"	3"	4"	5"	6"
Code	20	24	32	40	48	64	80	96

<b>VII</b>	<b>Coating</b>		
(None)	No Additional Coating		
NI	Nickel Plating		

### Dimension List

NPS	Part No	d	D	D1	D2	C	f	L	n-d1	Weight (Kg)
1"	VL-S-GA-F-150-16	18	108	79	51	14	1.3	127	4-Ø16	5.18
1 1/4"	VL-S-GA-F-150-20	23	116	89	63.5	16	1.3	140	4-Ø16	7.79
1 1/2"	VL-S-GA-F-150-24	29	126	98.5	73	17.5	1.3	165	4-Ø16	9.03
2"	VL-S-GA-F-150-32	51	150	120.7	92.1	14.3	2	178	4-Ø19	13.54
2 1/2"	VL-S-GA-F-150-40	65	180	139.7	104.8	15.9	2	190	4-Ø19	17.25
3"	VL-S-GA-F-150-48	76	190	152.4	127	17.5	2	203	4-Ø19	22.25
4"	VL-S-GA-F-150-64	102	229	190.5	157	22.3	2	229	8-Ø19	31.00

### Part Number Reference

Part No	Description
VL-S-GA-F-150-16	1" 150# SS316 FLANGE END GATE VALVE RF, RISING STEM,HANDWHEEL OPERATED
VL-S-GA-F-150-20	1 1/4" 150# SS316 FLANGE END GATE VALVE RF, RISING STEM,HANDWHEEL OPERATED
VL-S-GA-F-150-24	1 1/2" 150# SS316 FLANGE END GATE VALVE RF, RISING STEM,HANDWHEEL OPERATED
VL-S-GA-F-150-32	2" 150# SS316 FLANGE END GATE VALVE RISING STEM, HANDWHEEL OPERATED
VL-S-GA-F-150-40	2 1/2" 150# SS316 FLANGE END GATE VALVE RISING STEM, HANDWHEEL OPERATED
VL-S-GA-F-150-48	3" 150# SS316 FLANGE END GATE VALVE RISING STEM, HANDWHEEL OPERATED
VL-S-GA-F-150-64	4" 150# SS316 FLANGE END GATE VALVE RISING STEM, HANDWHEEL OPERATED



## AF HYDRO

### Conditions of Use of Catalogue:

The information in the catalogue are not binding and in order to improve distribution, AF Hydro reserves the right to make any change including size and pressure ratings considered necessary at any time and without prior notice. According to the copyright and the civil law, any reproduction (also partial) of figures and texts of this catalogue by means of electronic, mechanical, photocopies, microfilms, recordings or other is forbidden without AF Hydro's authorization.